

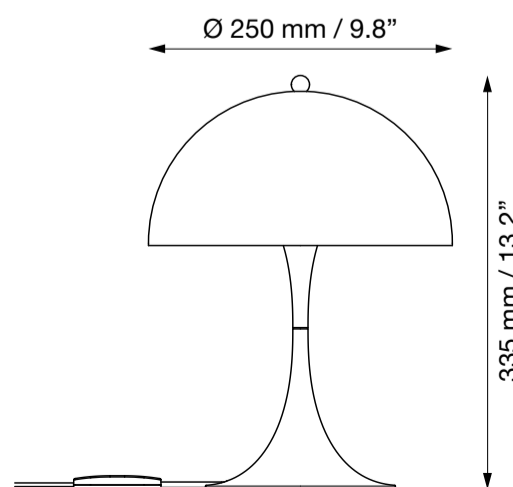





louis poulsen

PANTHELLA 250 TABLE LAMP

DESIGNED BY
VERNER PANTON



Lyskilde Light source Leuchtmittel Ljuskälla Sorgenti luminose Source lumineuse Fuente de luz Valonlähde 광원 光源	Spænding/frekvens Voltage/frequency Spannung/frequenz Spänning/frekvens Tensione/frequenza Voltage/frequence Tensión/frecuencia Jännite/taajuus 전압/주파수 電壓/頻率	Vægt Weight Gewicht Vikt Peso/ingombro Poids Peso Paino 무게 重量	Isolationsklasse Protection Class Schutzklasse Isolationsklass Classe di isolamento Protection au choc électrique Clase de aislamiento Eristysluokka 보호 등급 防护等级	Tæthedsklasse Ingress protection Schutzart Kapslingsklass Grado di protezione Indice de protection Clase de protección Koteloitiluokka 방진방수 入口保护
LED  	AC100-240V, 50/60HZ	Max. 1,2 kg/2.6 Lbs	Cl. II	IP20
LED  	DC 12V  SELV	Max. 1,2 kg/2.6 Lbs	Cl. III	IP20

DA

Støv aftørres med en tør, blød klud. Fedtpletter og lignende kan fjernes med en blød klud opvredet i lunkent vand (<50° C) tilsat mildt rengøringsmiddel. Brug aldrig rengøringsmidler, der indeholder slibemiddel, opløsningsmidler, alkohol eller syre.

EN

Wipe off dust with a dry, soft cloth. Remove greasy spots etc. with a soft cloth dampened in lukewarm water (<50° C) with a mild detergent. Never use detergents containing abrasives, solvents, alcohol or acid.

DE

Staub bitte mit einem trockenen, weichen Lappen abwischen. Fettflecke und dgl. mit einem feuchten, in lauwarmem Wasser (<50° C) mit mildem Reinigungsmittel ausgewrungenen Lappen entfernen. Verwenden Sie niemals Reinigungsmittel, die Schleifmittel, Lösungsmittel, Alkohol oder Säure enthalten.

SV

Lampan dammtorkas med en torr, mjuk trasa. Fettfläckar tas bort med ljummet vatten (<50° C) utblandat med mildt rengöringsmedel. Använd aldrig rengöringsmedel som innehåller slipmedel, lösningsmedel, alkohol eller syra.

IT

Pulire la polvere esterna con un panno morbido e asciutto. Rimuovere macchie di grasso ecc. con un panno morbido inumidito in acqua tiepida (<50° C) e con un detergente leggero. Non utilizzare mai detersivi contenenti abrasivi, solventi, alcool o acidi.

FR

Essuyez la poussière avec un chiffon sec et doux. Enlevez les points de saleté etc. avec un chiffon doux imprégné d'eau claire tiède et de détergent doux. N'employez jamais de détergents contenant des substances abrasives, des solvants, de l'alcool ou de l'acide.

ES

Limpiar con paño seco y suave. Quitar manchas de grasa y otras con paño suave humedecido con agua templada (<50° C) con detergente poco agresivo. No utilice nunca detergentes que contengan agentes abrasivos, disolventes, alcohol o ácido.

FI

Pyyhi pölyt kuivalla pehmeällä liinalla. Poista rasvatahrat miedolla pesuaineella ja haalealla vedellä (<50° C) kostutetulla pehmeällä liinalla. Älä koskaan käytä puhdistusaineita, jotka sisältävät hankaavia aineita, liuottimia, alkoholia tai happoa.

JP

ホコリは乾いた柔らかい布で拭き取ってください。塗装部分の油污れ等は、中性洗剤を溶かしたぬるま湯(50℃以下)に柔らかい布を浸し、よくしぼってから拭き取ってください。シンナー・ベンジン等の揮発物や、つや出し剤・研磨剤、溶剤、アルコール、酸を含む洗剤は絶対に使用しないでください。

Replaceability & Energy Efficiency Class



DA
Dette produkt indeholder en lyskilde i energieffektivitetsklasse E

EN
This product contains a light source of energy efficiency class E

DE
Dieses Produkt enthält eine Lichtquelle der Energieeffizienzklasse E

SV
Denna produkt innehåller en ljuskälla med energieffektivitetsklass E

IT
Questo prodotto contiene una sorgente luminosa di classe di efficienza energetica E

FR
Ce produit contient une source lumineuse de classe d'efficacité énergétique E

ES
Este producto contiene una fuente luminosa de la clase de eficiencia energética E

FI
Tämä tuote sisältää valonlähteen, jonka energiatehokkuusluokka on E

JP
この製品には、エネルギー効率クラス E の光源が含まれています。



DA
Lyskilden i dette armatur må kun udskiftes af producenten eller en uddannet elektriker. Hvis den eksterne fleksible ledning eller kablet til dette armatur beskadiges, skal det udskiftes af producenten, dennes servicerepræsentant eller en person med tilsvarende kvalifikationer for at undgå farlige situationer.



EN
The light source contained in this luminaire must only be replaced by the manufacturer or a qualified electrician. If the external flexible cable or cord of this luminaire is damaged, it must only be replaced by the manufacturer or his service agent or a similar qualified person in order to avoid hazardous situations.



DE
Das in dieser Leuchte enthaltene Leuchtmittel sollte nur vom Hersteller oder von einem qualifizierten Elektriker ausgetauscht werden. Im Fall einer Beschädigung des externen flexiblen Leuchtenkabels darf der Austausch des Kabels aus Sicherheitsgründen ausschließlich durch den Hersteller oder eine vom Hersteller benannte Servicestelle oder eine Fachkraft mit geeigneter Qualifikation erfolgen.



SV
Ljuskällan i denna armatur ska endast bytas ut av tillverkaren eller en kvalificerad elektriker. Om den externa flexibla ledningen till armaturen skadas ska den endast bytas ut av tillverkaren eller dennes servicerepresentant eller liknande kvalificerad person för att undvika fara.



IT
La sorgente contenuta in questa parte illuminante sarà solo riposizionata dal produttore o da un elettricista esperto. Se il cavo esterno flessibile dell'apparecchio è danneggiato, dovrà essere sostituito esclusivamente dal produttore, dal servizio assistenza o da personale qualificato per evitare qualsiasi pericolo.



FR
La source lumineuse de ce luminaire ne peut être remplacée que par le fabricant ou un électricien qualifié. Si le cordon ou le câble flexible externe de ce luminaire est endommagé, il doit être exclusivement remplacé par le fabricant, son représentant ou une personne qualifiée afin d'éviter tout danger.



ES
Si el cable flexible externo de esta luminaria se dañara, debería ser reemplazado únicamente por el fabricante, o por su agente autorizado, o por una persona cualificada para así evitar peligros. La sustitución de la fuente de luz que contiene esta luminaria debe ser llevada a cabo exclusivamente por el fabricante o un electricista profesional.



FI
Tämän valaisimen valonlähteen saa vaihtaa ainoastaan valmistaja tai koulutettu sähköasentaja. Vaaratilanteiden välttämiseksi valaisimen vahingoittuneen ulkoisen joustavan kaapelin tai johdon saa vaihtaa vain valmistaja, valtuutettu huoltoliike tai vastaava pätevä taho.



JP
この照明器具のLEDは、一般のランプのように取り換えができません。不点の場合は当社にお問い合わせください。この照明器具のケーブルやコードが損傷した場合、速やかに電源を切り、当社または販売店にご相談ください。

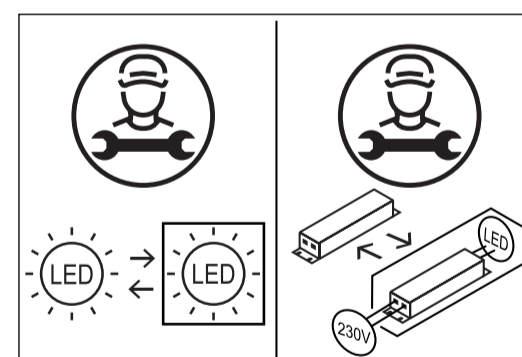

LOUIS POULSEN A/S
KUGLEGAARDSVEJ 19-23,
1434 COPENHAGEN K, DENMARK
TEL. +45 70 33 14 14
INFO@LOUISPOULSEN.DK
WWW.LOUISPOULSEN.COM



louis poulsen

ESTABLISHED 1874

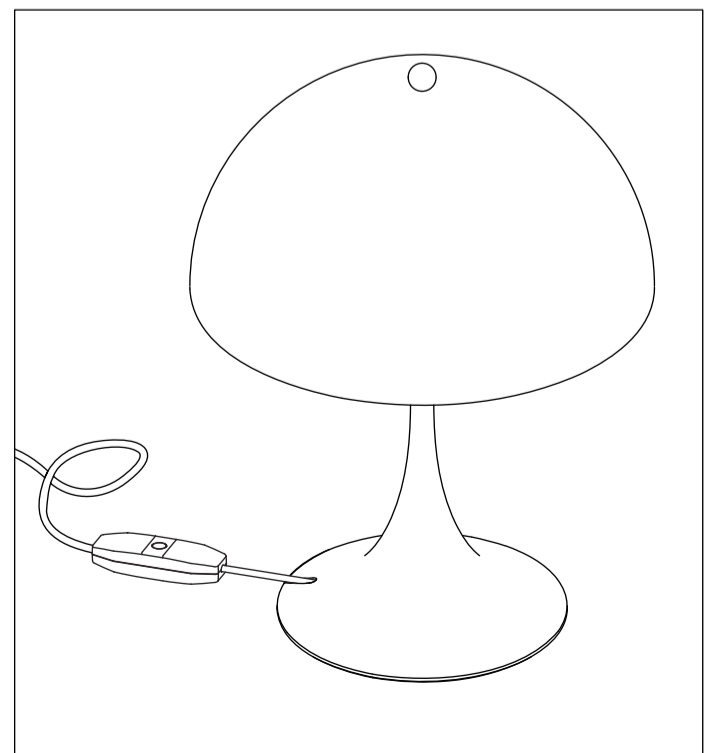
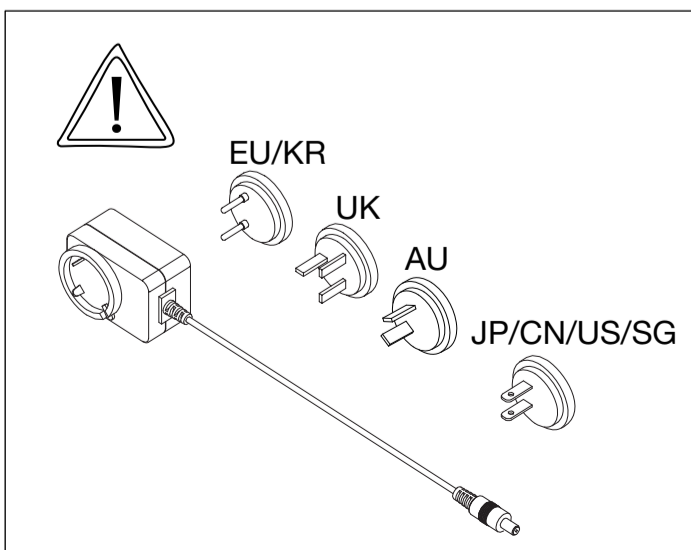
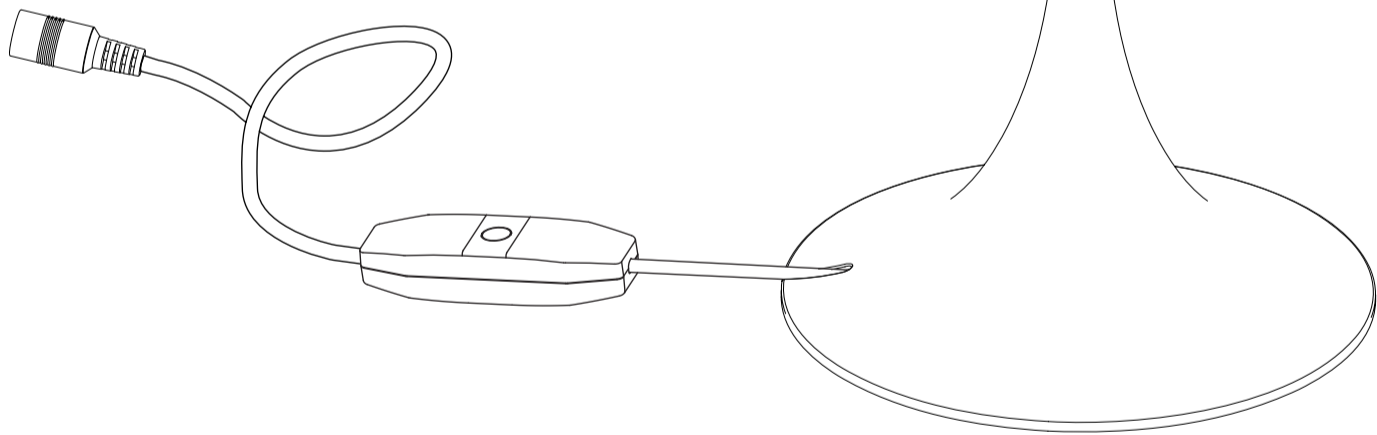
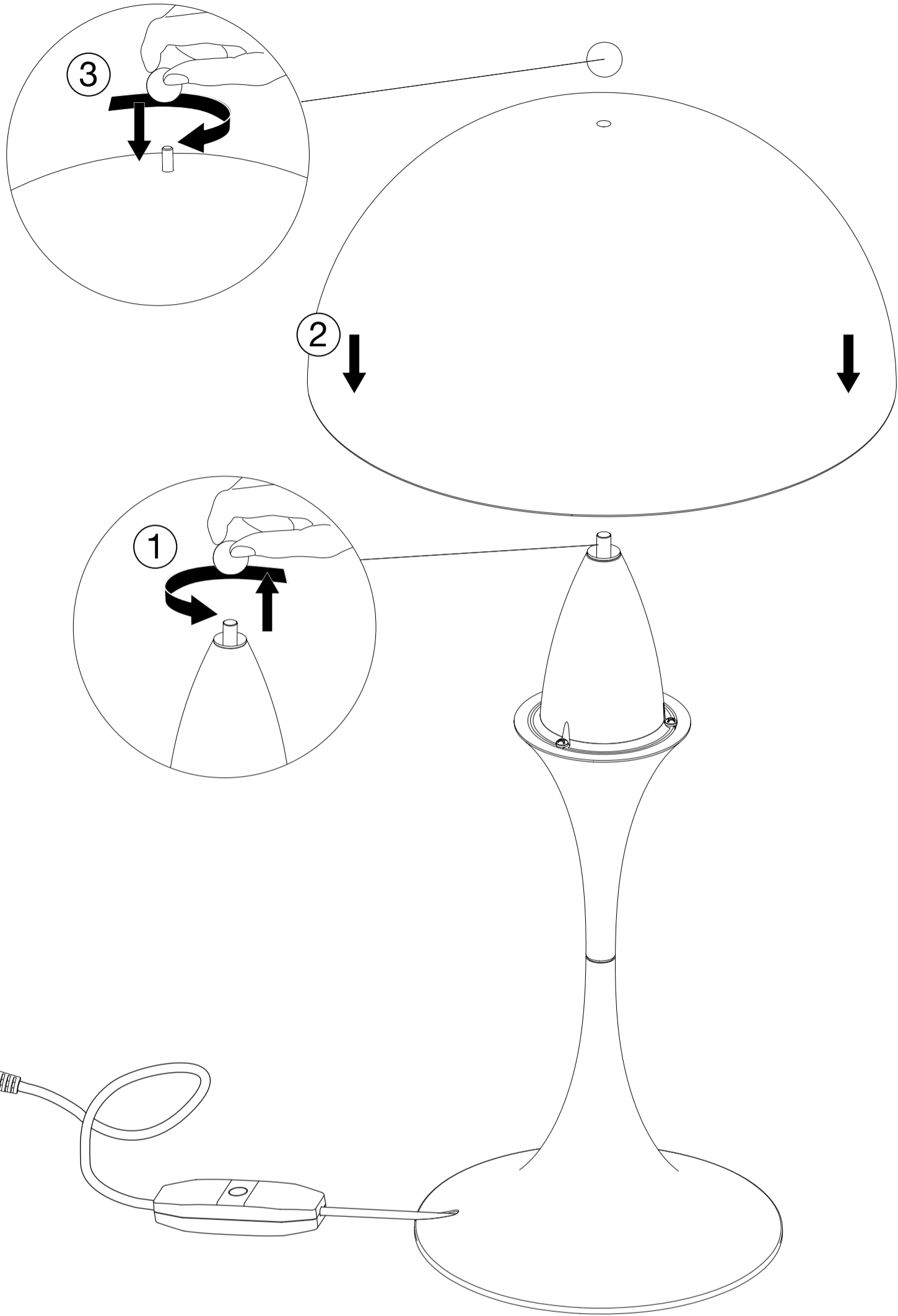
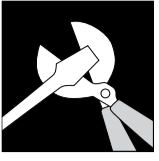

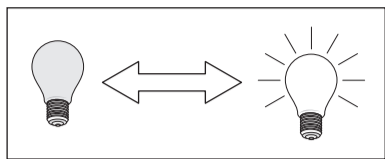

Power on/off:

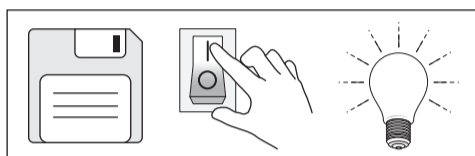
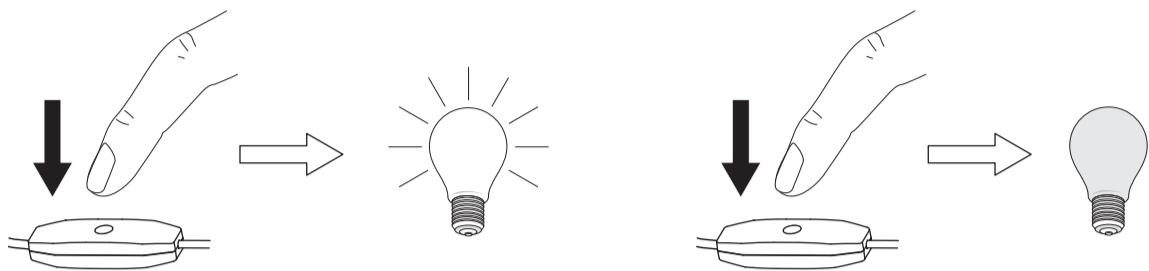

Set default brightness level when connected to power:

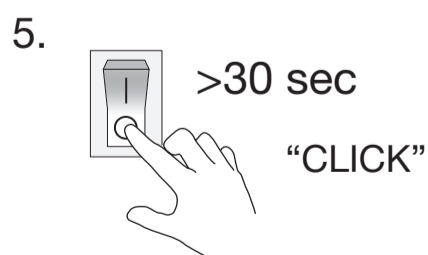
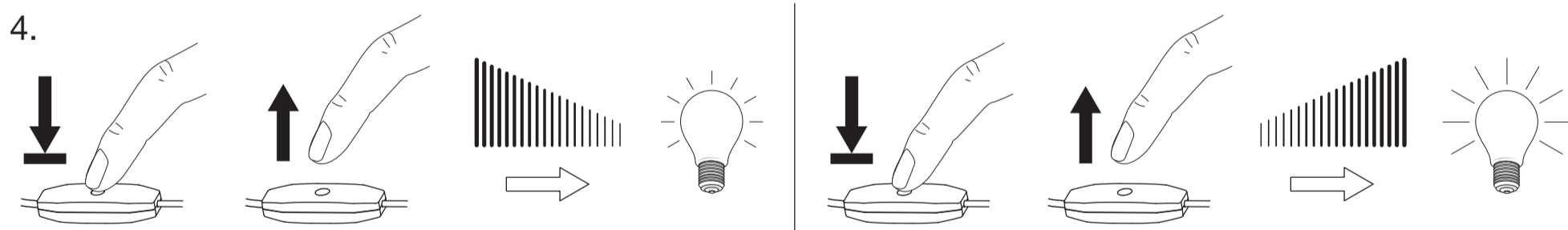
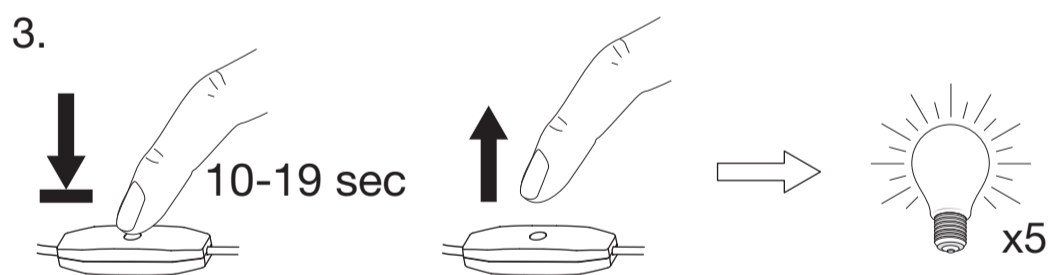
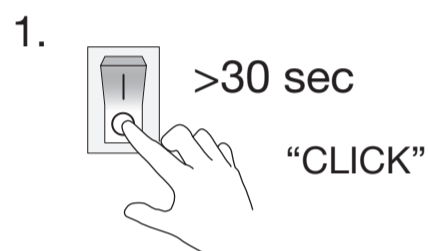

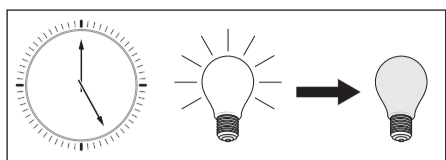

Set timer to automatically turn off lamp after period of time:

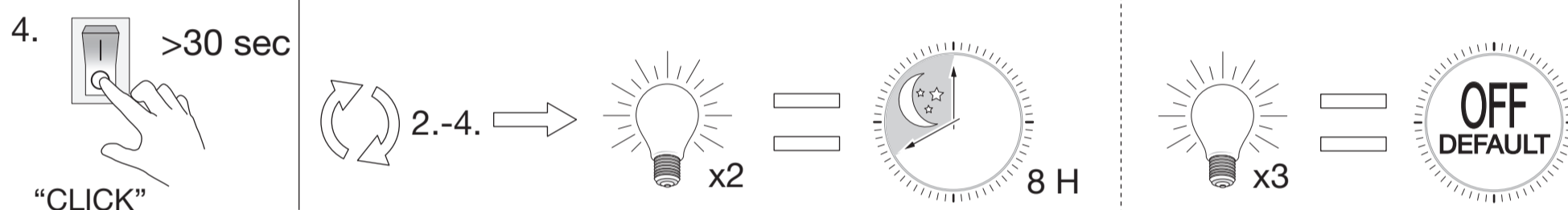
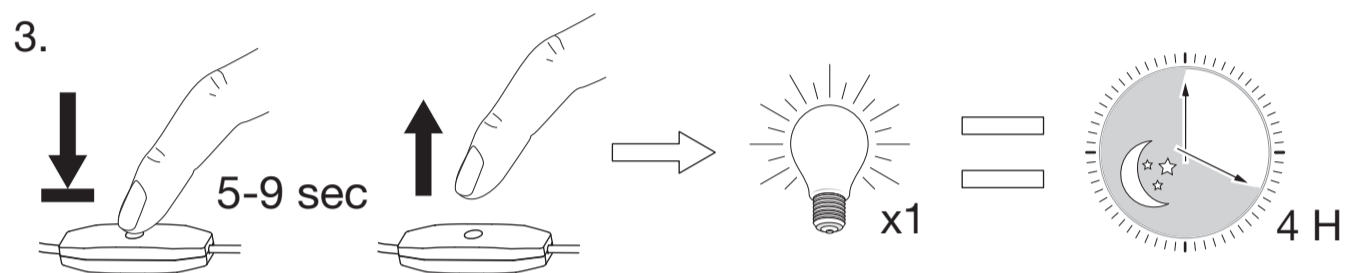
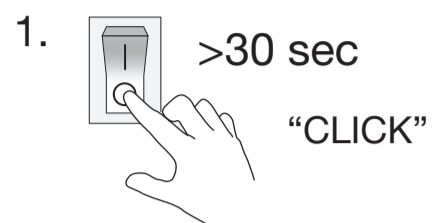

Restore factory default settings:

