

**jorel**

Design: Philipp Mainzer

**interlübke**

**Montageanleitung  
Assembly instruction**

Bitte montieren Sie die Möbel nach den Hinweisen in der Aufbauanleitung und den Aufklebern auf den Möbeln. Beachten Sie auch die in der Aufbauanleitung angegebenen Maße der Befestigungsmaterialien. Prüfen Sie sorgfältig, ob die von uns mitgelieferten Schrauben und Universaldübel für die bauseits vorhandene Beschaffenheit der Zimmerwand ausreichend sind. Im Zweifelsfall den baulichen Gegebenheiten entsprechende Schrauben oder Dübel verwenden oder andere, sichere Befestigungsart wählen.

Überzeugen Sie sich gewissenhaft vom festen Sitz aller einzelnen Verankerungen. Aufgeklebte Sicherheitsbestimmungen beachten. Elektroanschlüsse nur nach gültigen VDE-Bestimmungen vornehmen. Für nicht vorschriftsmäßig aufgebaute Möbel übernehmen wir keine Haftung. Wichtiger Hinweis für den Benutzer der Möbel: Bitte alle Befestigungen von Zeit zu Zeit prüfen. Der Inhalt der Beschlagtüten ist standardisiert und gilt für verschiedene Typen. Von Fall zu Fall können einzelne Beschläge oder Schrauben übrigbleiben. Alle interlübke-Produkte erfüllen hohe Qualitätsanforderungen. Grundstoffe wie Trägermaterialien oder Lacke entsprechen und unterschreiten den bei Drucklegung gültigen deutschen Emissions-Verordnungen.

It is imperative that the enclosed assembly instructions and attached safety stickers are followed carefully. Particular care must be taken to ensure that the condition of the wall to which the furniture is attached on site is capable of accepting the enclosed screws and rawplugs. In case of doubt other screws and rawplugs corresponding to the material of the construction or alternative fixing parts should be used. Please follow safety instructions carefully. No liability is accepted for non compliance with instructions. To user of furniture: please test security of wall fixings from time to time. The contents of the fitting bags have been standardised to be useable for a variety of types. From time to time therefore it is possible that one or two items may be left over.

All interlübke products are produced to the highest technical specifications. All raw materials and lacquers used meet the stringent German environmental control regulations.

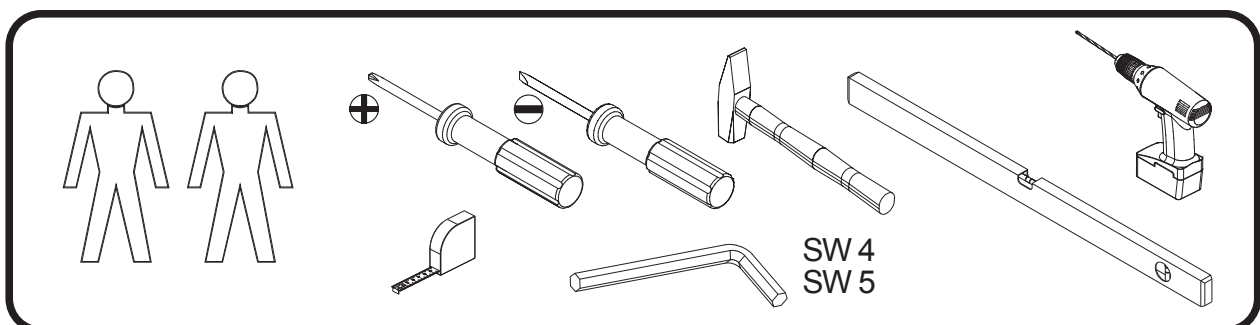

<b>Inhaltsverzeichnis</b> <b>Contents</b>	<b>Seite</b> <b>page</b>
D fachgerecht auspacken EN Professional unpacking	2
D Modulmontage Tür- / Türkorpus EN Assembly door/door module	3
D Modulmontage SK- / Türkorpus EN Assembly drawer/door module	4
D Modulausrichtung EN Module adjustment	5
D Kippsicherung EN Anti-tipping device	6
D Raumteiler Kippsicherung EN Anti-tipping device room divider	7
D Wandhängende Sideboards EN Wall-mounted sideboards	8 - 9
D Abdeckplatte EN Top closing panel	10
D Schubkasten Ausrichten EN Drawer adjustment	11
D Drehtür Ausrichten EN Door adjustment	12
D Inneneinteilung EN Interiors	13
D Bar Spiegel und Glasböden montieren EN Installation bar mirror and glass shelves	14 - 15
D Pflegemittel für Edelstahl silvertouch und Naturstein EN Maintenance products for stainless steel in silvertouch and natural stone	16

jorel

fachgerecht auspacken  
professional unpacking

interlübke

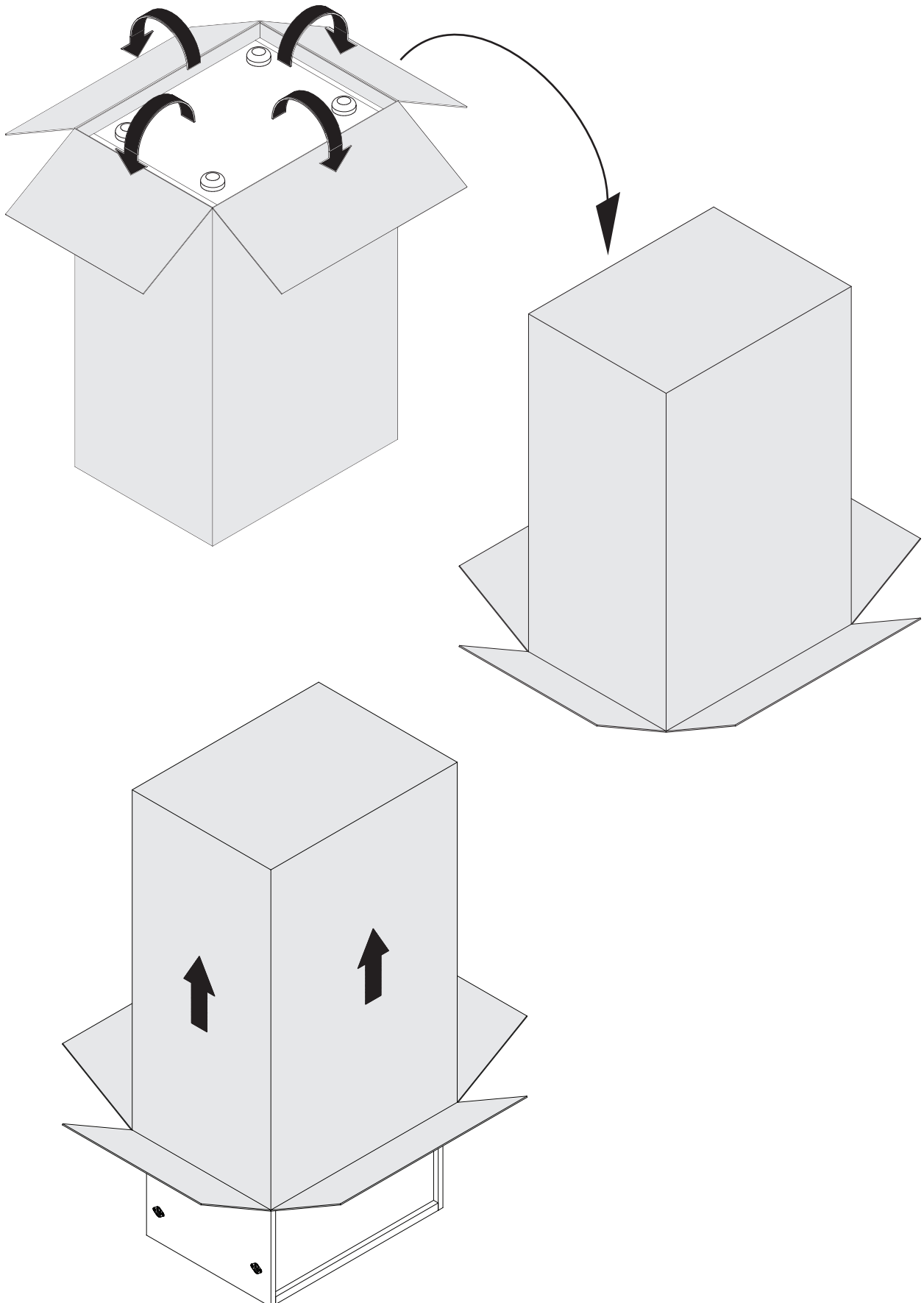

jorel

interlücke

Montage Abdeckseiten  
Mounting Covering

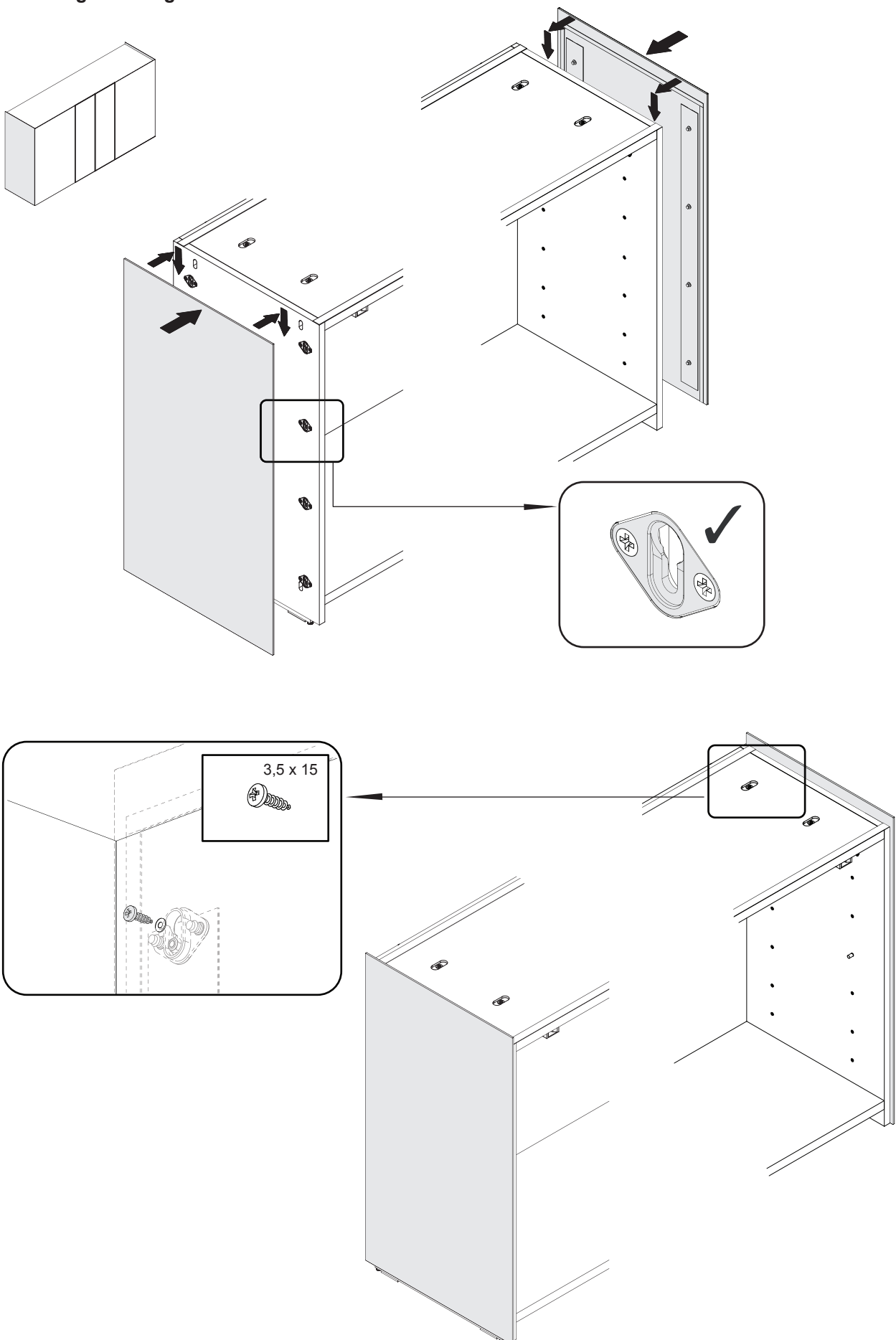

jorel

interlücke

seitliche Verbindung Türkorpus zu Türkorpus  
lateral connection door carcass to door carcass

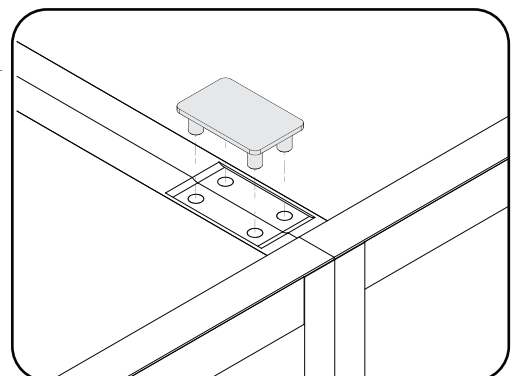
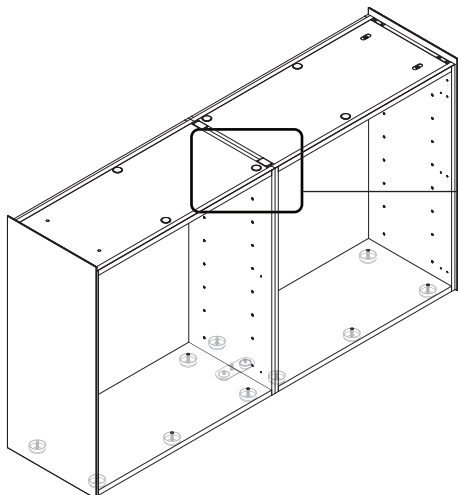
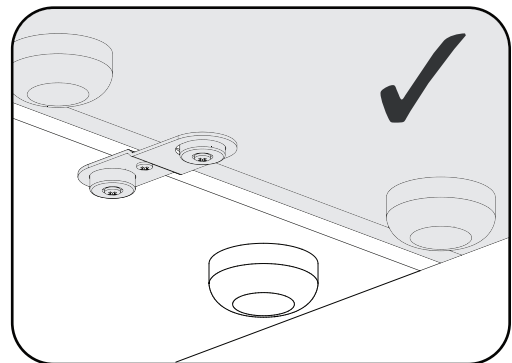
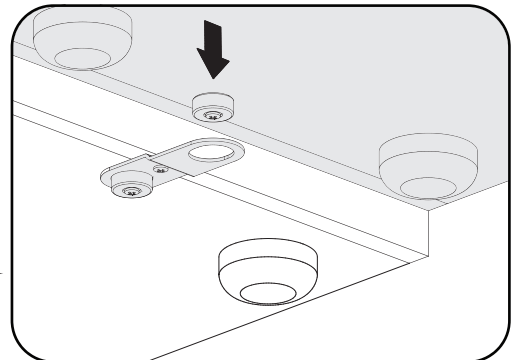
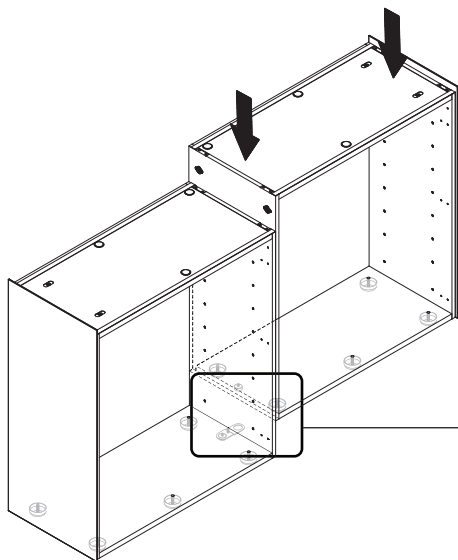
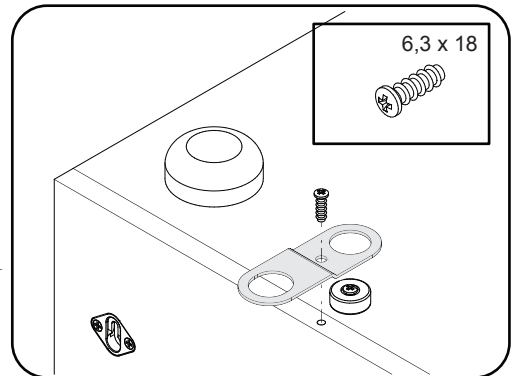
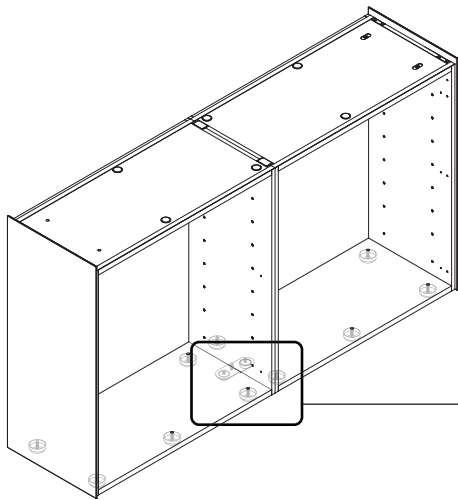

jorel

interlücke

seitliche Verbindung Schubkastenkorpus zu Türkorpus  
lateral connection door carcass to door carcass

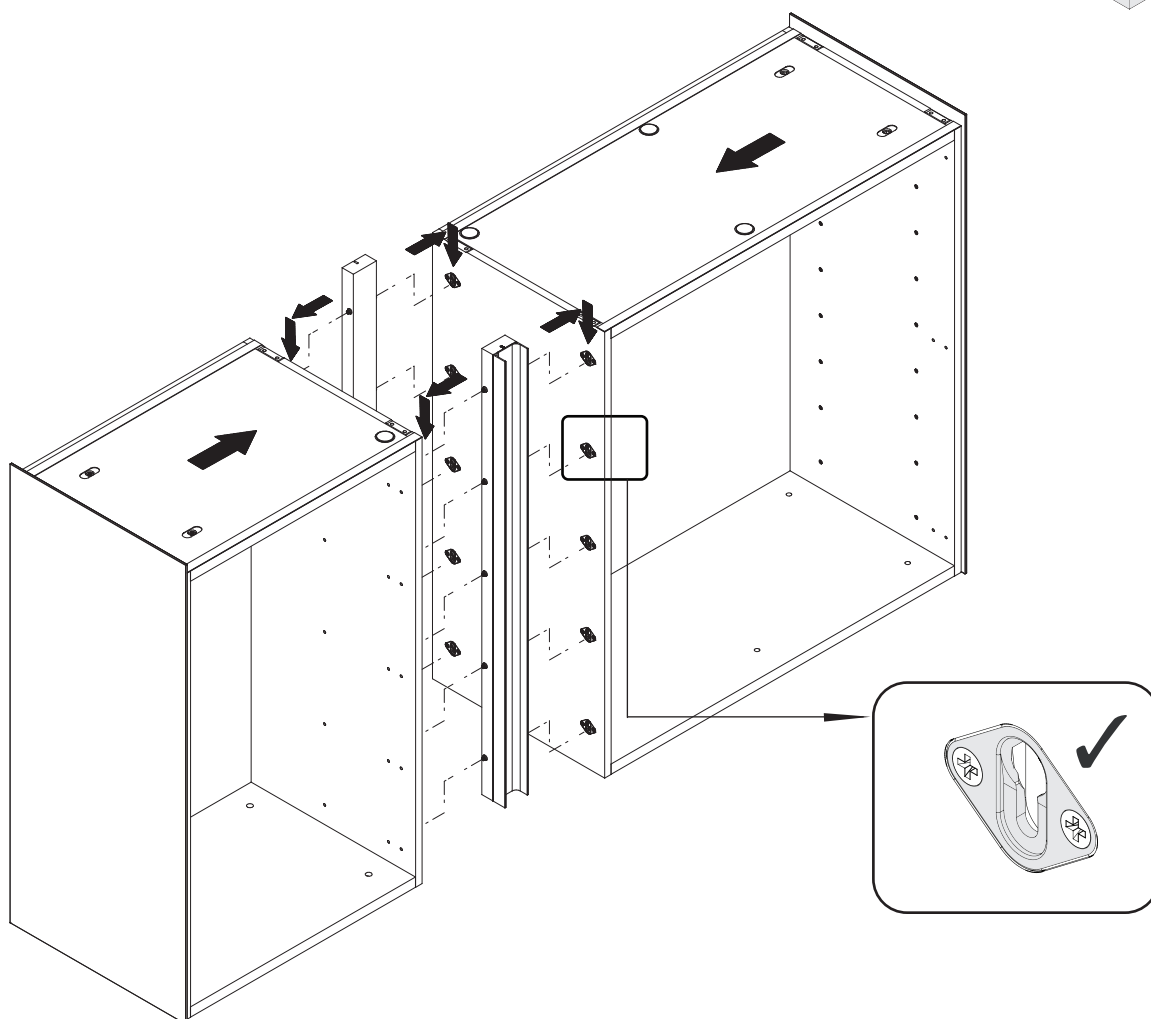
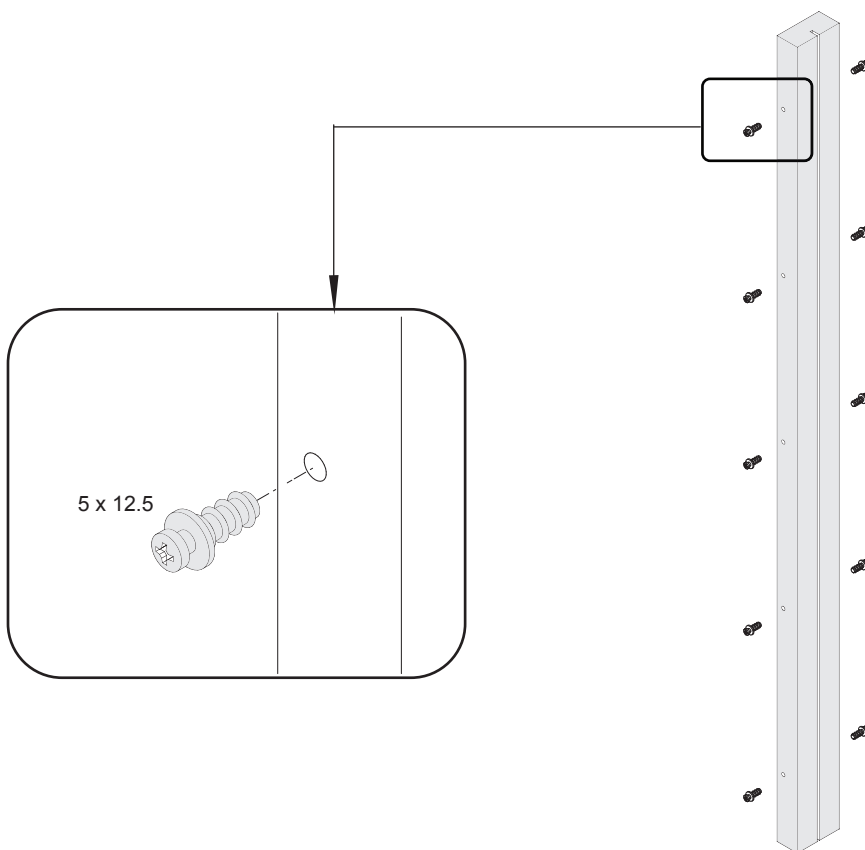
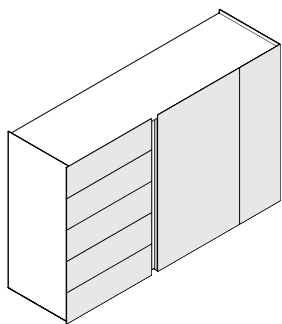

jorel

interlücke

Ausrichtung  
Adjustment

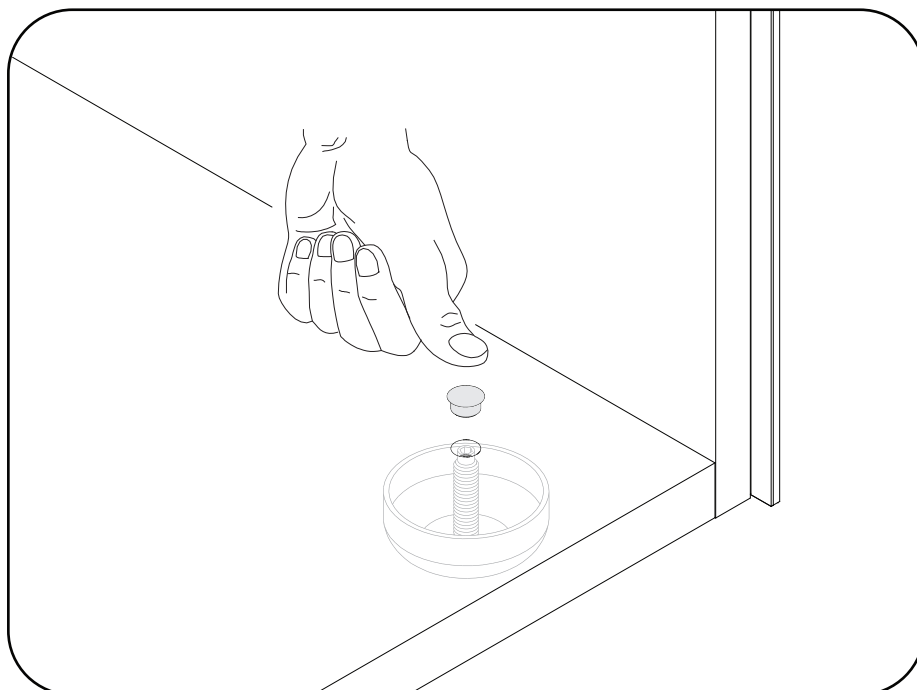
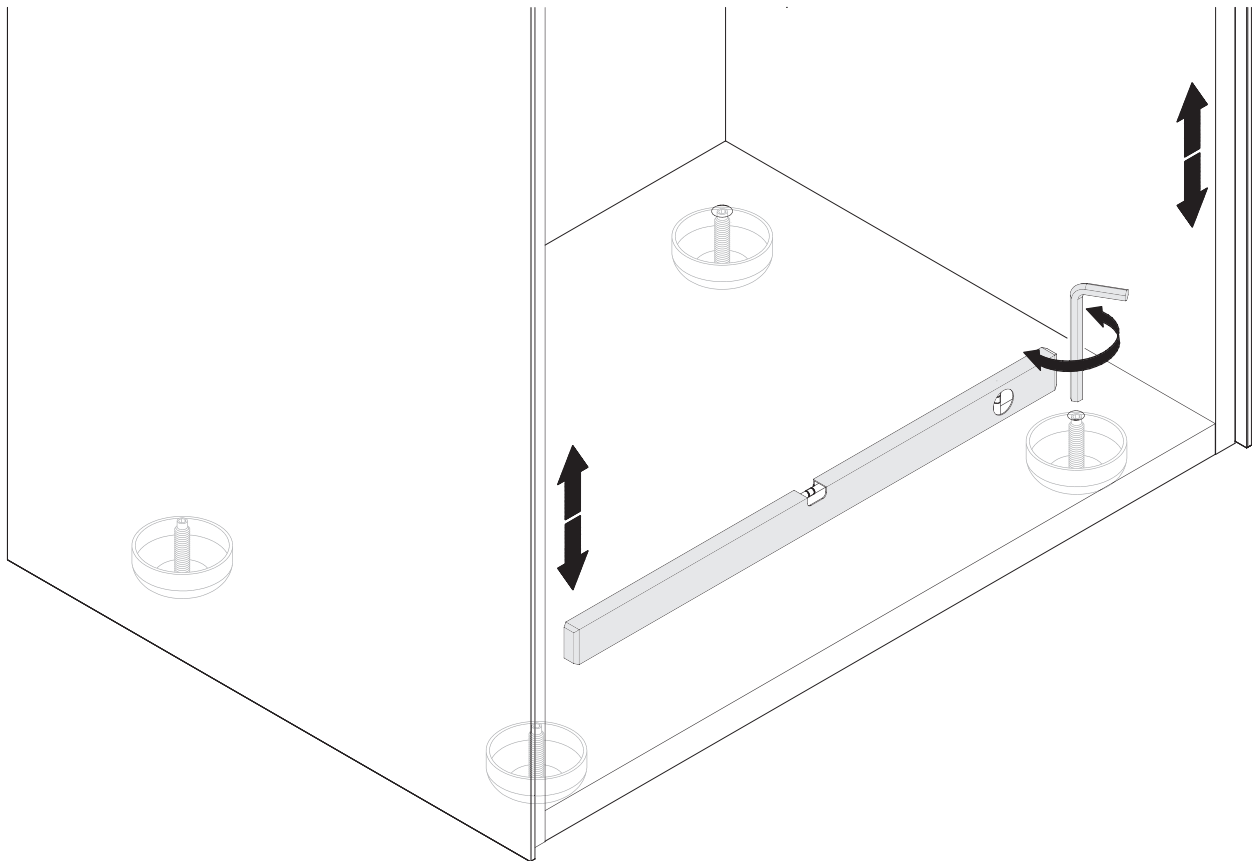



jorel

interlücke

Kippsicherung  
Anti-tipping device

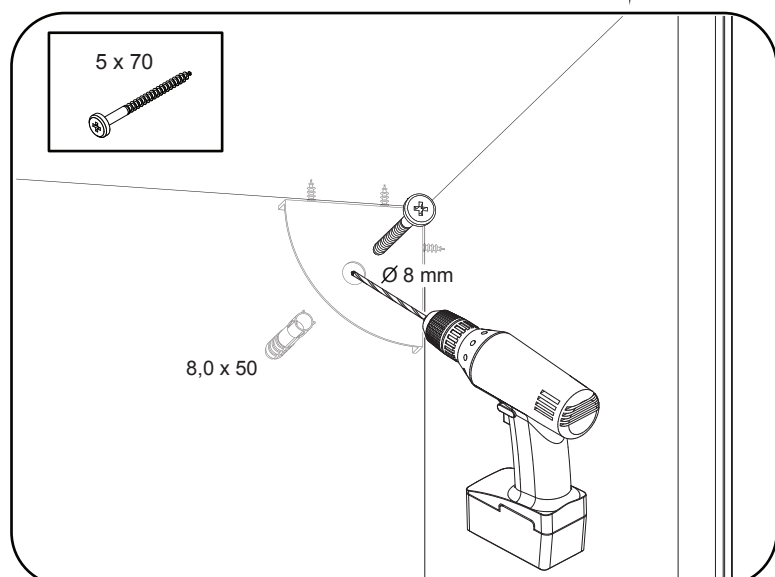
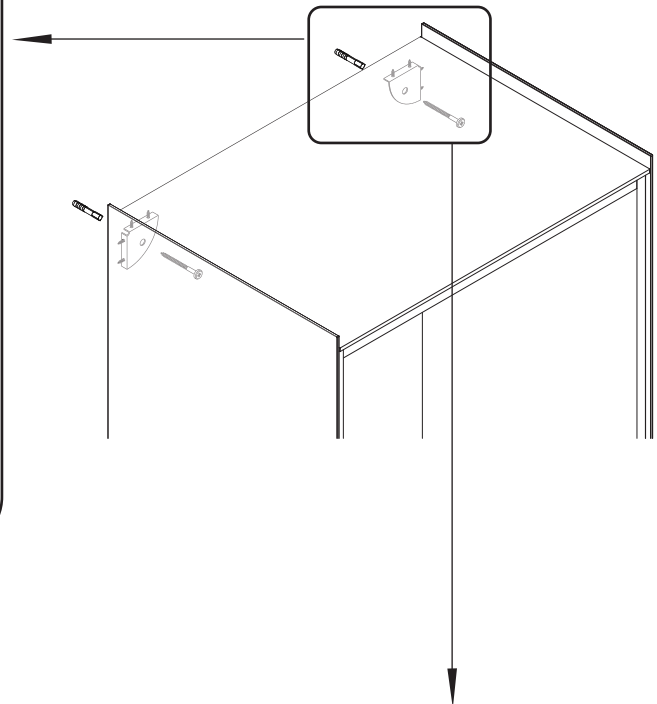
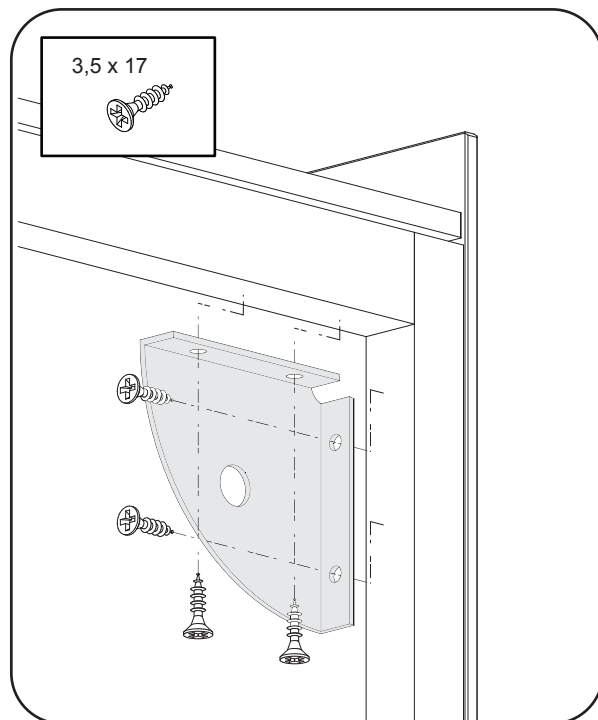
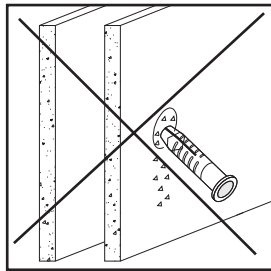
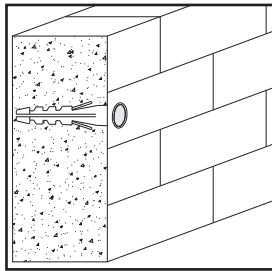

jorel

interlücke

Raumteiler Kippsicherung  
Anti-tipping device room divider

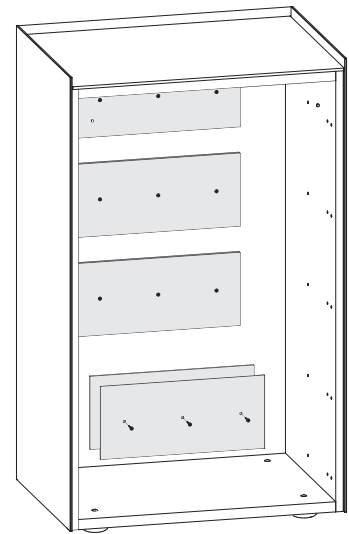
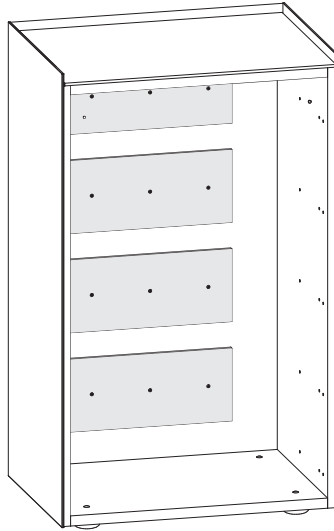
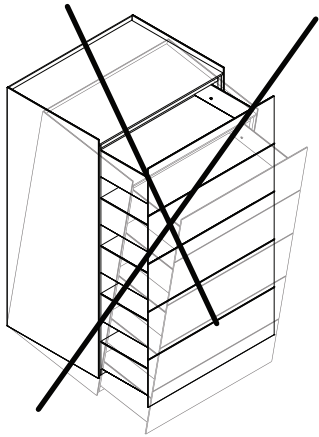

- |  |        |
|--|--------|
| 2 Raster Höhe 60er Breite / Height 2 modules, width 60 | 4 St.  |
| 3 Raster Höhe 60er Breite / Height 3 modules, width 60 | 6 St.  |
| 3 Raster Höhe 90er Breite / Height 3 modules, width 90 | 12 St. |
| 4 Raster Höhe 60er Breite / Height 4 modules, width 60 | 7 St.  |
| 4 Raster Höhe 90er Breite / Height 4 modules, width 90 | 14 St. |
| 5 Raster Höhe 60er Breite / Height 5 modules, width 60 | 8 St.  |
| 5 Raster Höhe 90er Breite / Height 5 modules, width 90 | 16 St. |

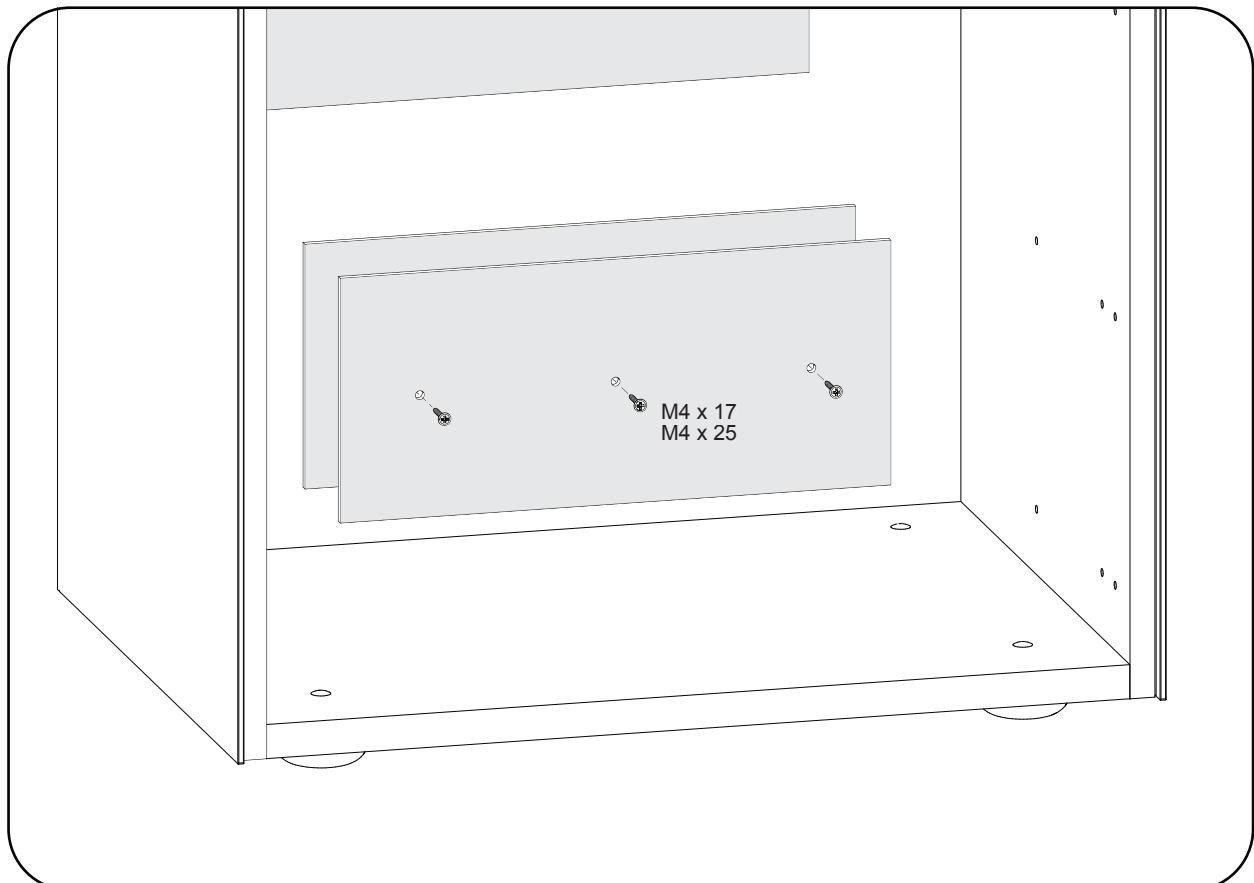

jorel

interlücke

Wandhängende Sideboards  
Wall-mounted sideboards

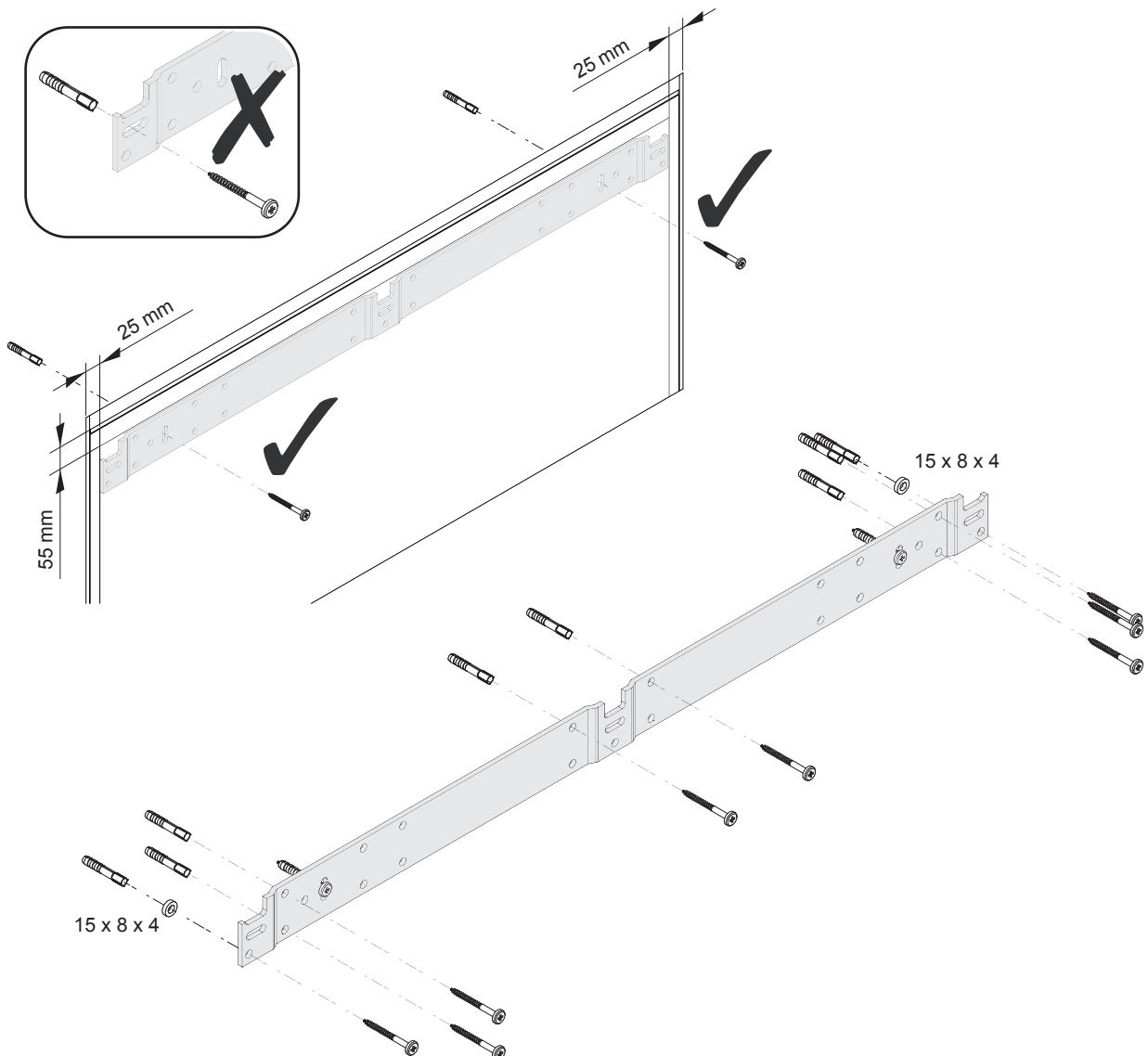
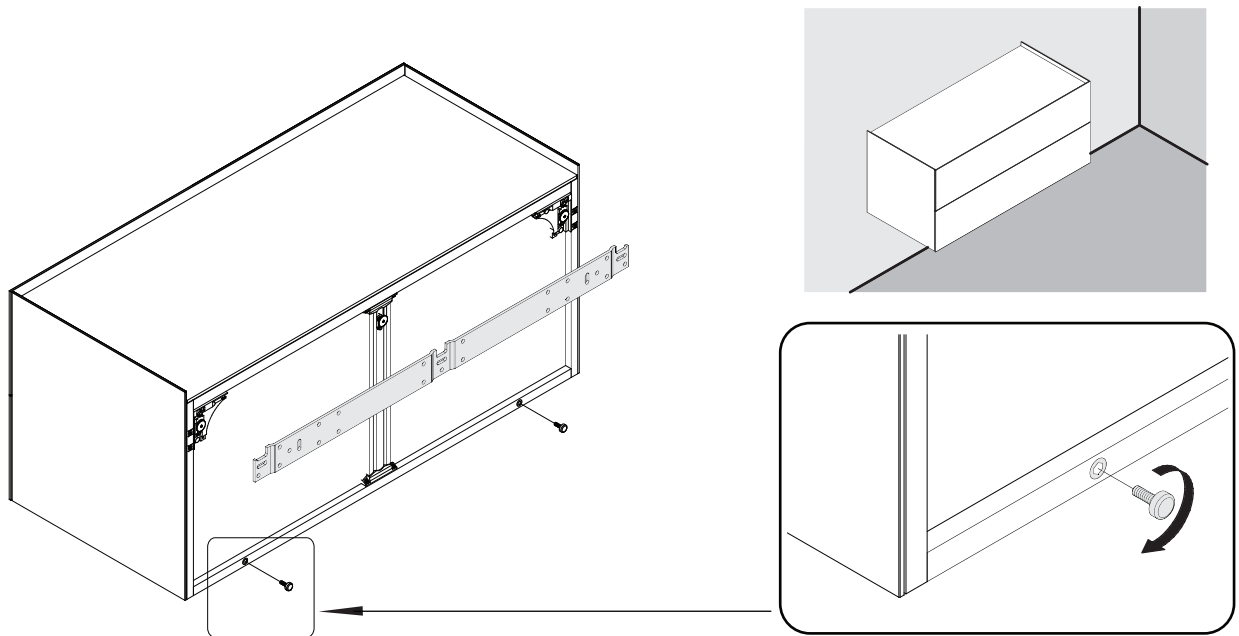

jorel

Wandhängende Sideboards  
Wall-mounted sideboards

interlücke

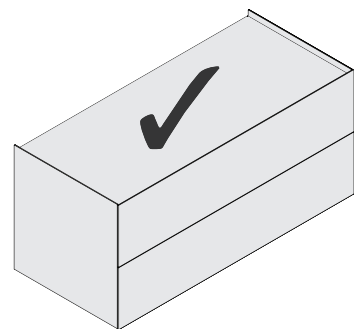
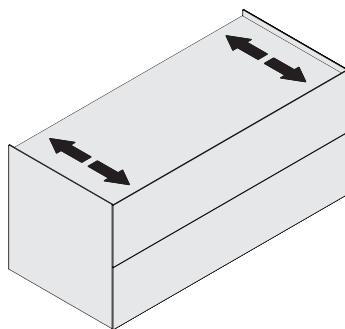
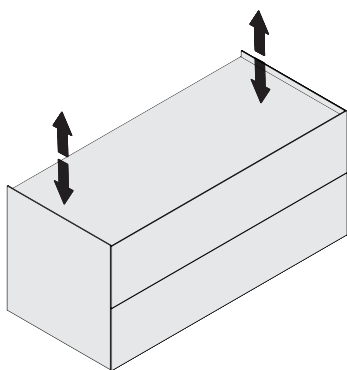
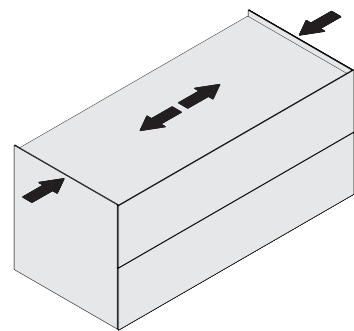
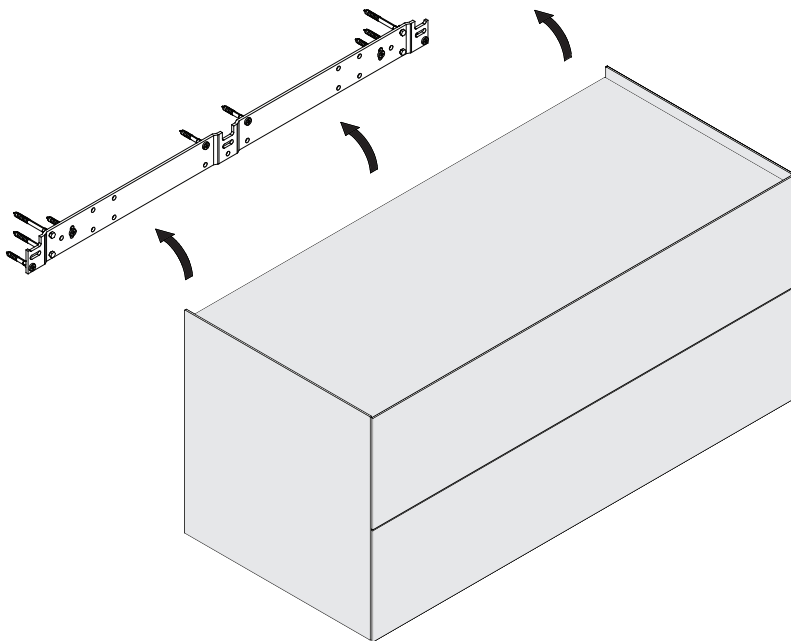

Aushängsicherung!  
anti turn-over locking!

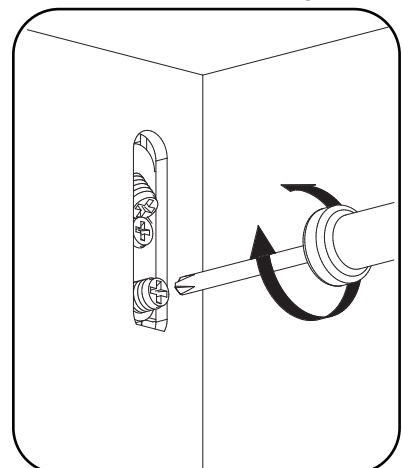
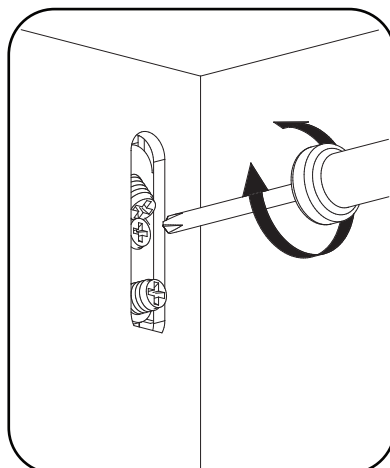
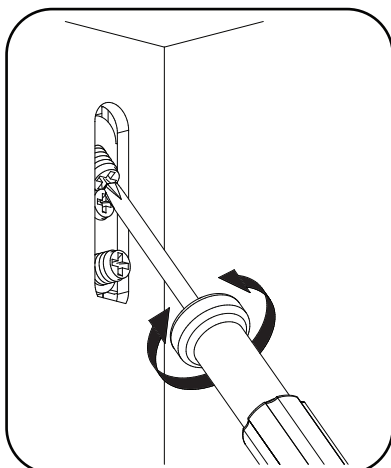

jorel

interlücke

Abdeckplatte  
Top closing panel

**Achtung:**  
Die zu beklebende Fläche muß Staub- und Fettfrei sein.  
**Attention:**  
The surface for the sticker must be free of dust and grease.

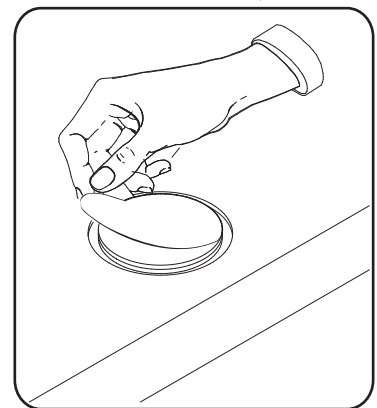
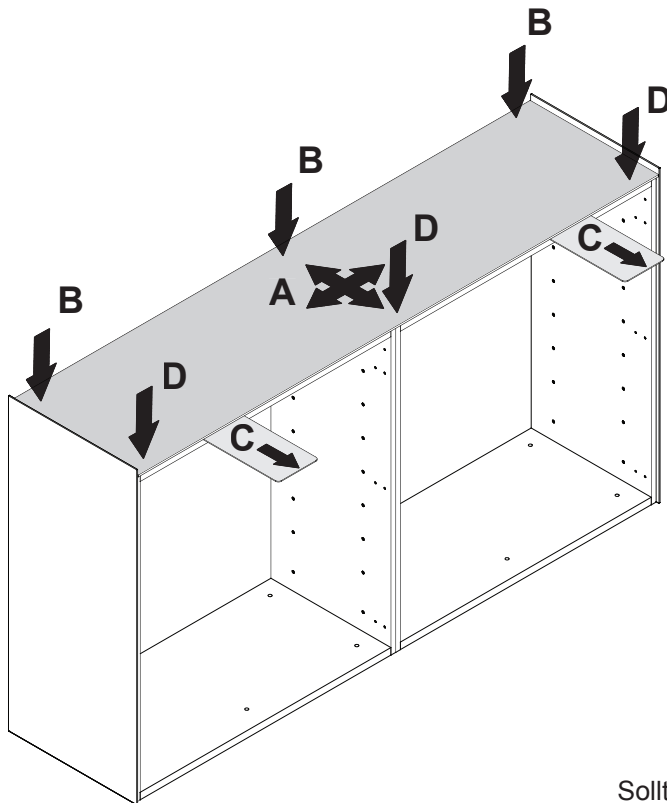
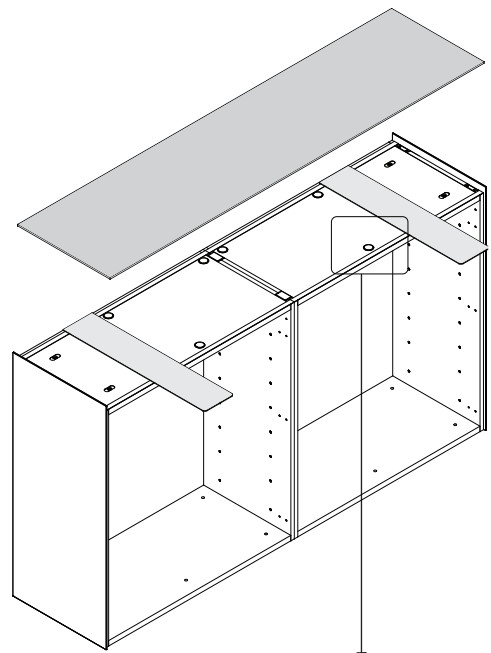

Sollte eine weitere Feinjustierung erforderlich sein.  
Abdeckplatte **frühestens nach 5 Min.** abheben.  
For further adjustment, lift off the panel after 5 min. at the earliest

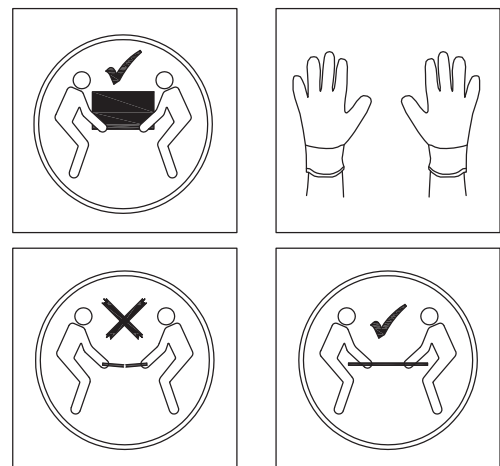
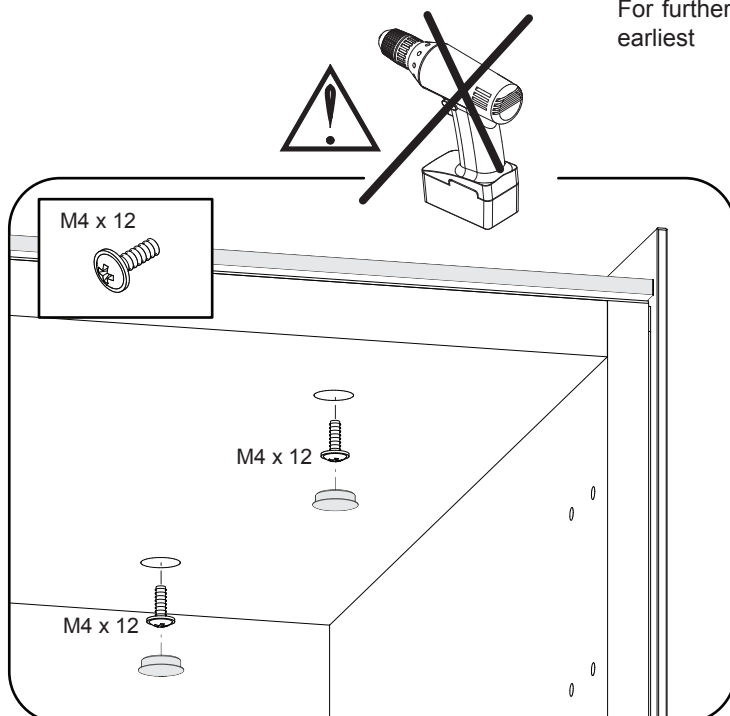

Schubkasten Ausrichten  
Drawer adjustment

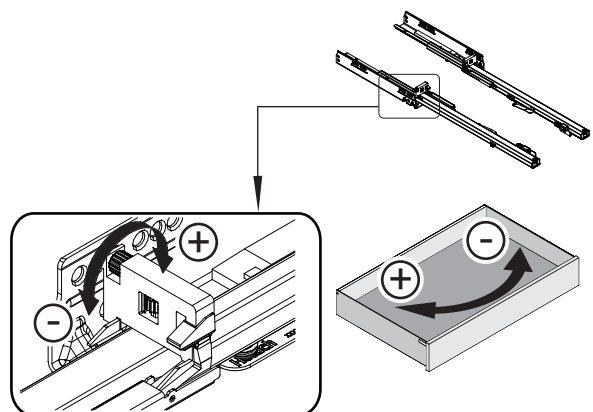
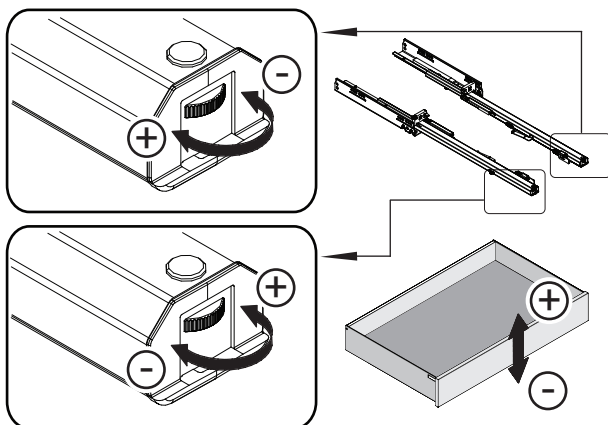
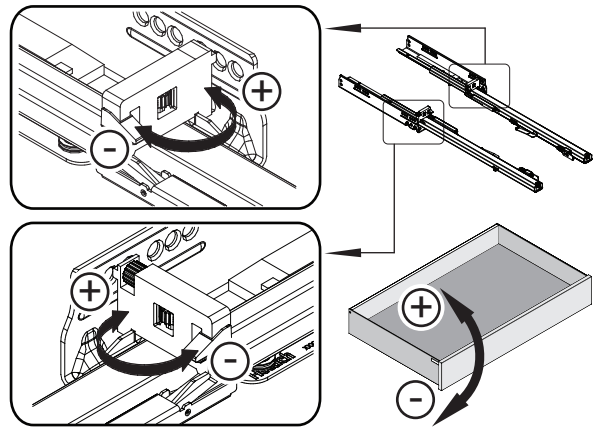
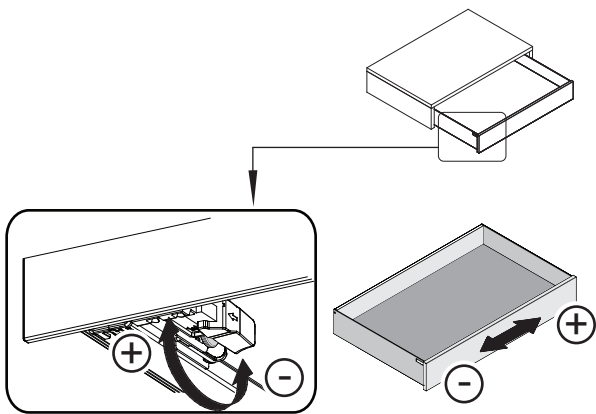
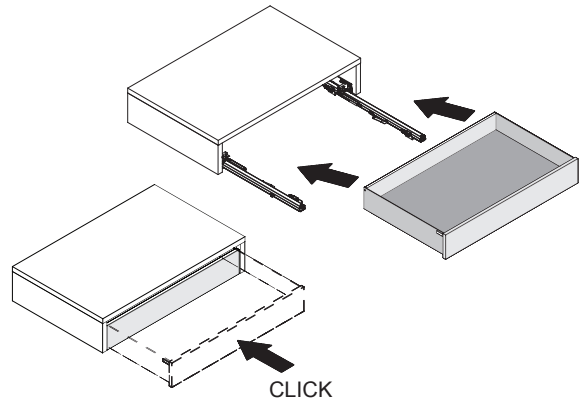
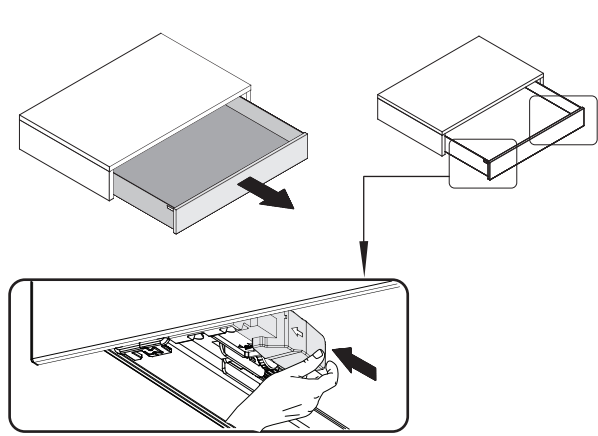

jorel

interlücke

Ausrichten Türen  
Adjustment door

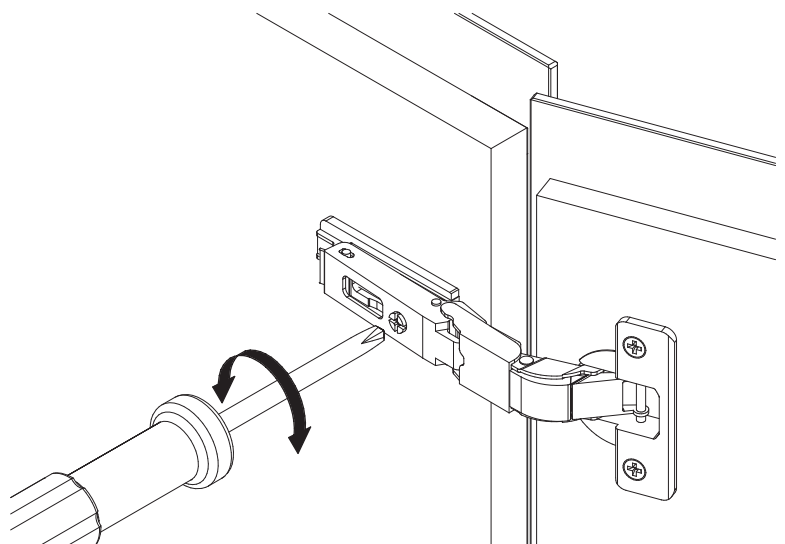
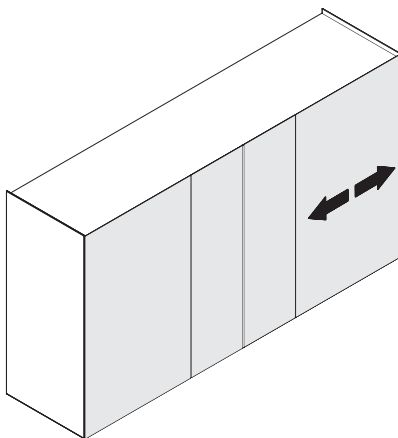
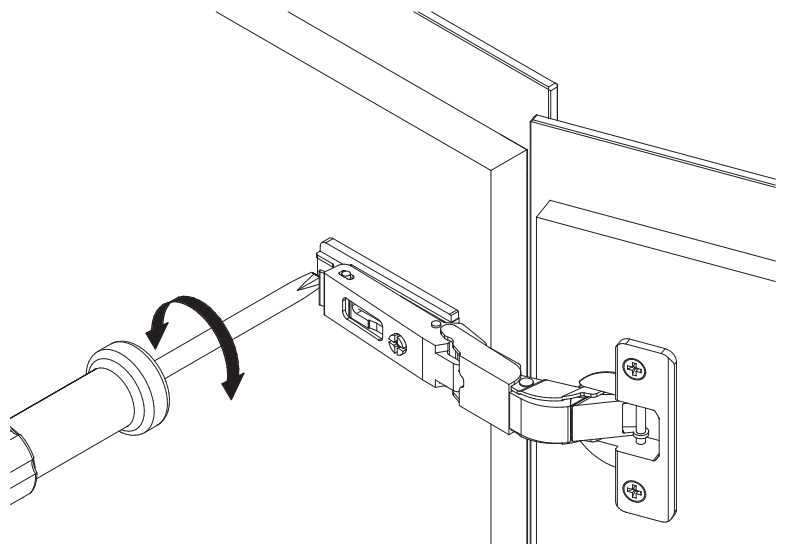
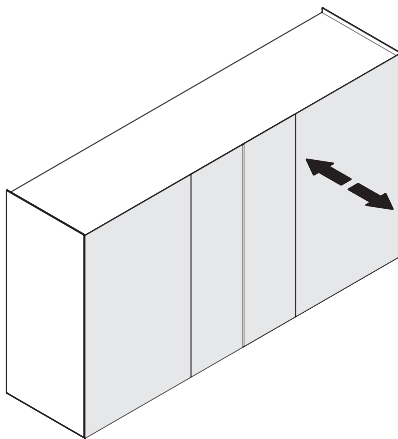
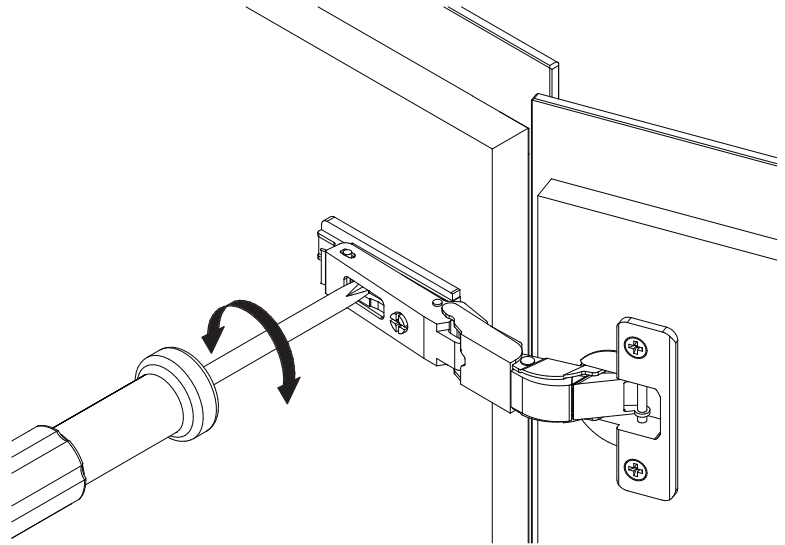
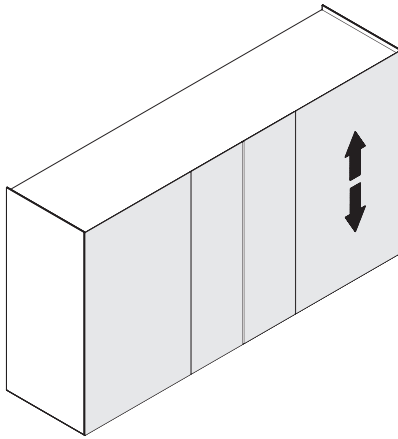

jorel

Inneneinteilung  
Interiors

interlücke

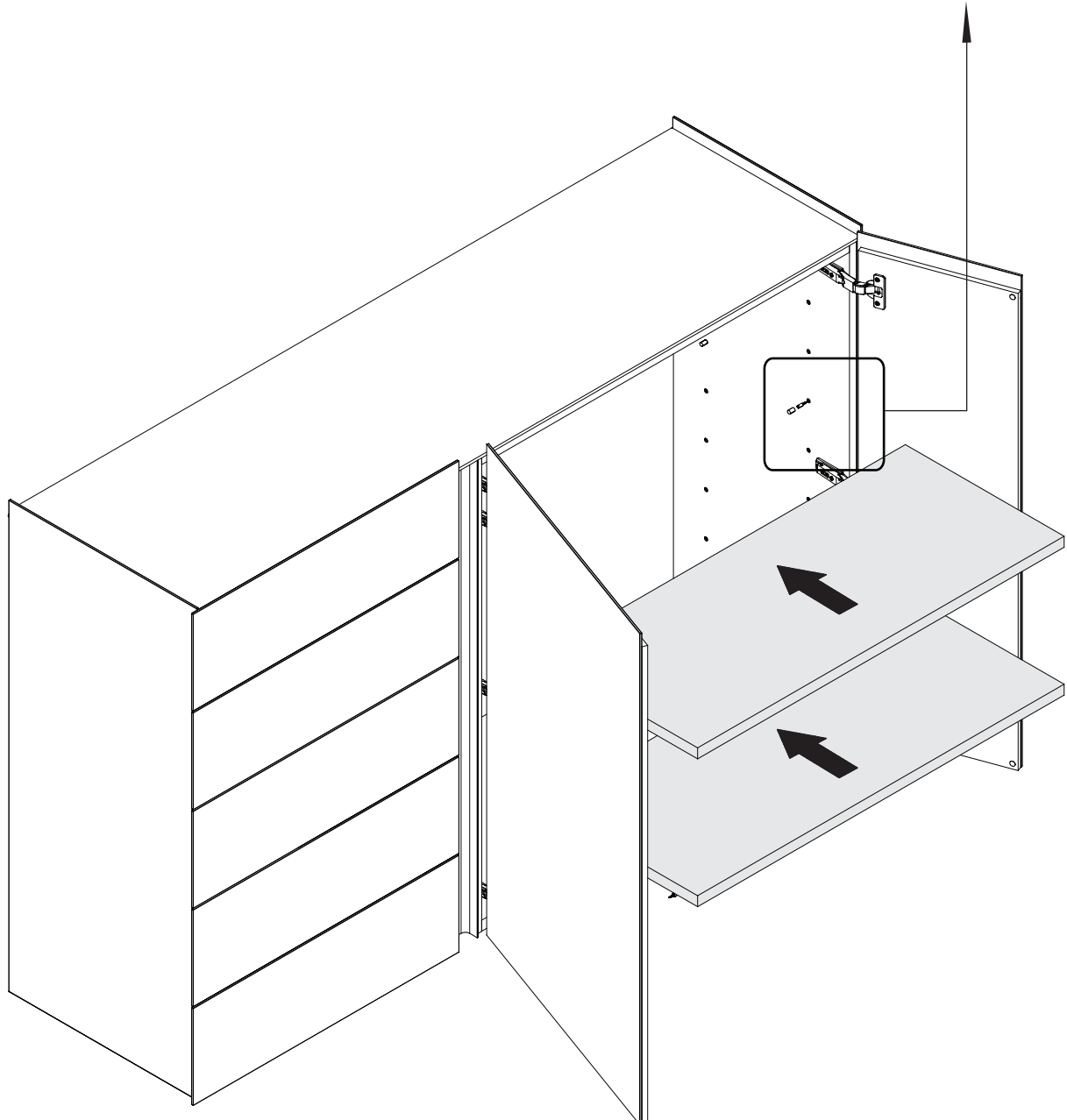
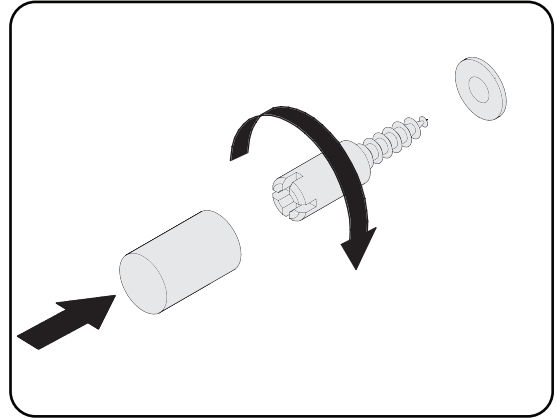
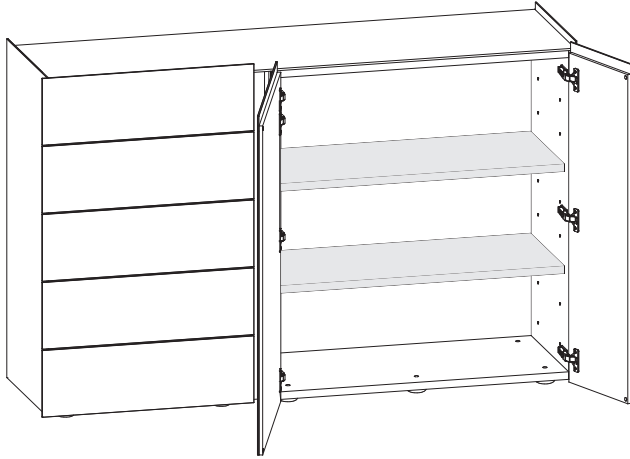



jorel

interlücke

Spiegel und Glasböden montieren  
Installation mirror and glass shelves

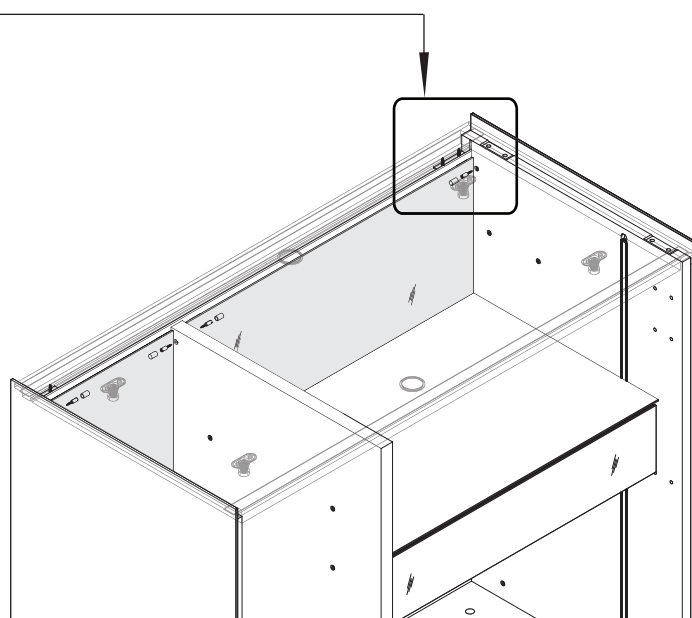
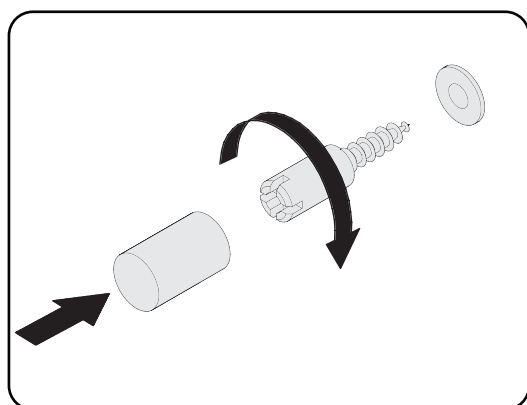
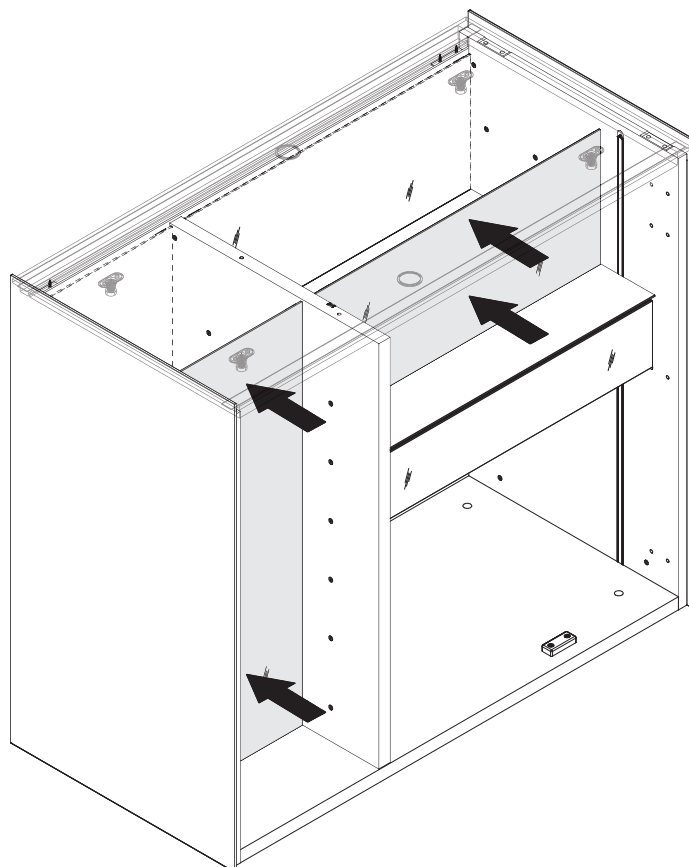
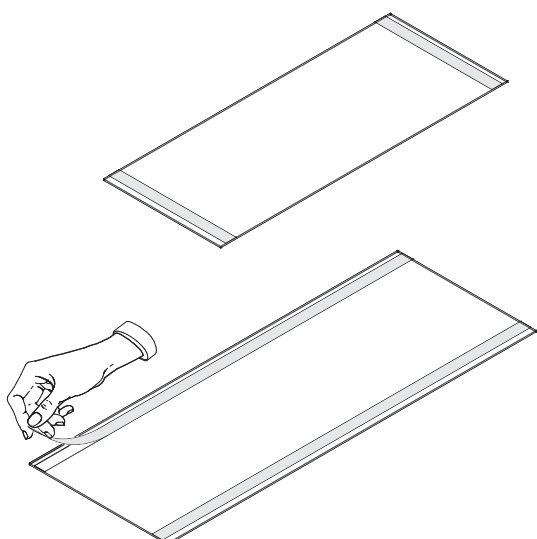
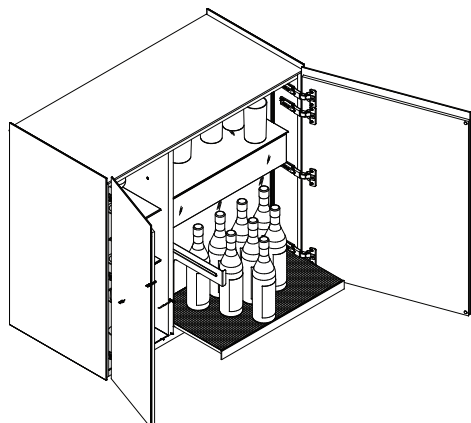

Spiegel und Glasböden montieren  
Installation mirror and glass shelves

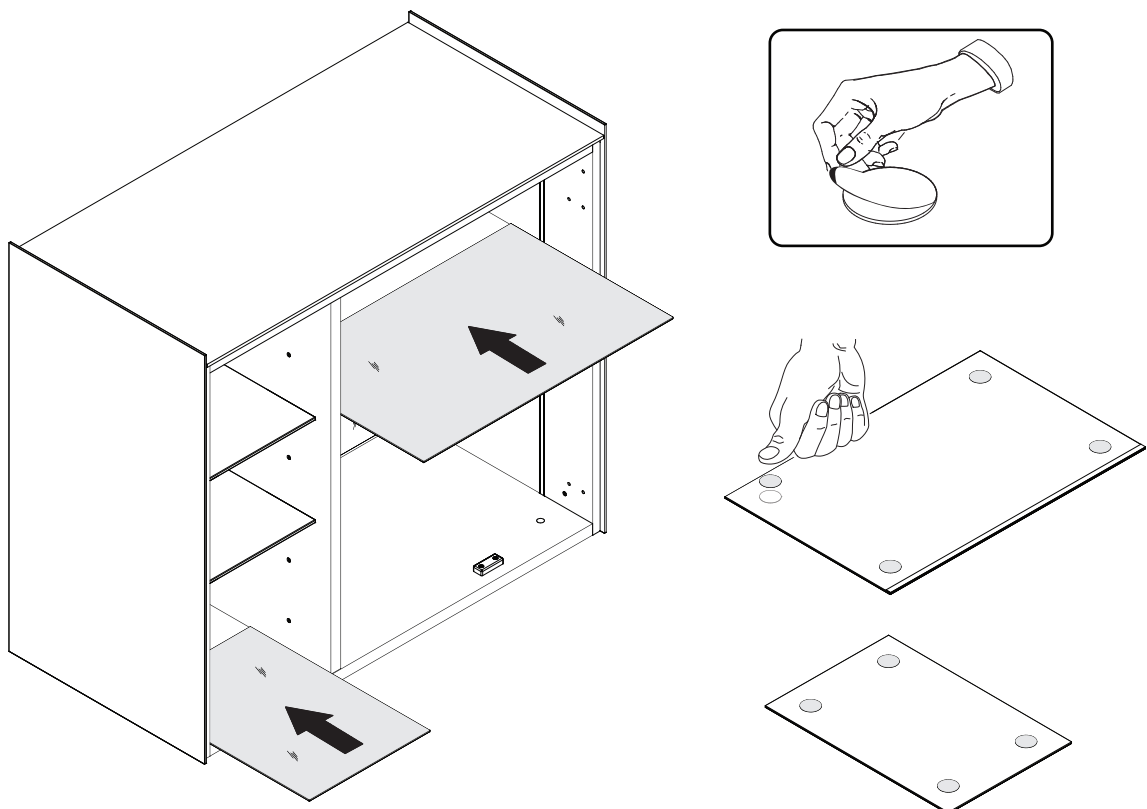
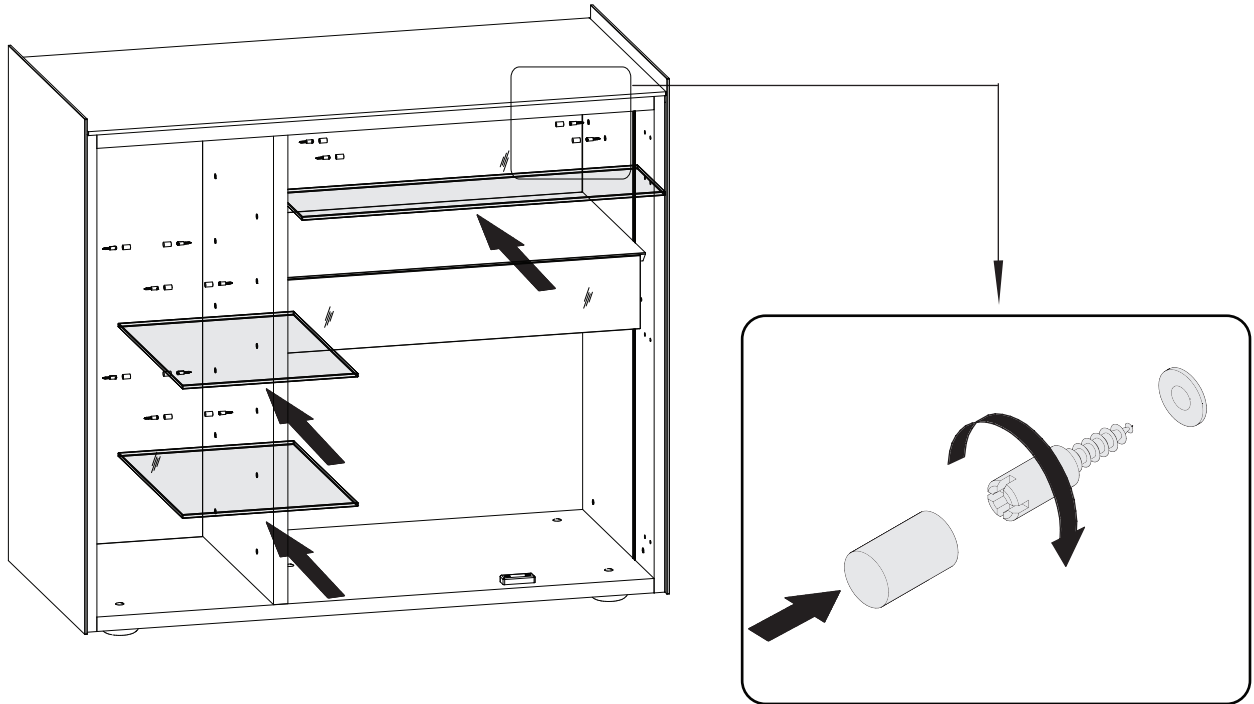

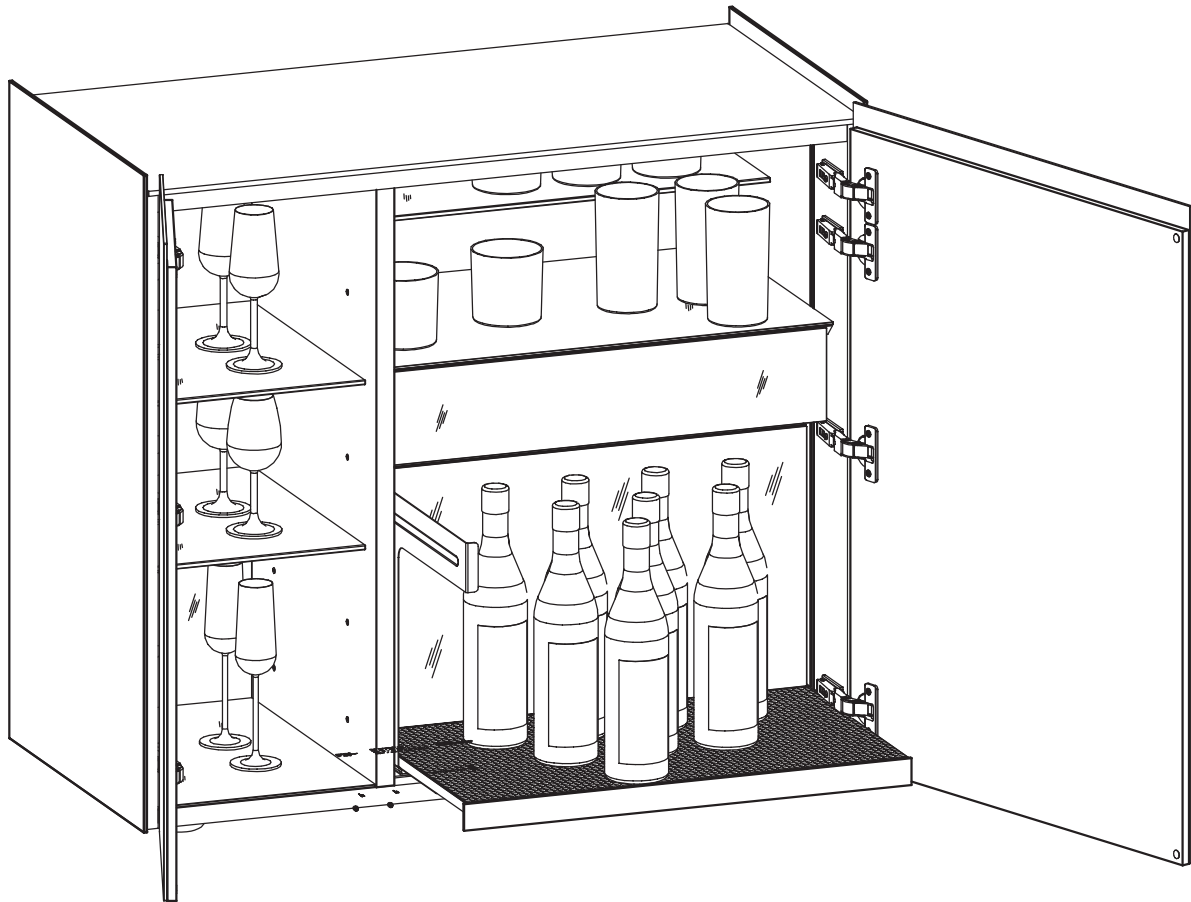

**Funksender (weiß temperaturgeregelt)  
radio-controlled switch  
EL01337**

Der Funksender benötigt 2x AAA Batterien  
bitte dem Karton entnehmen und richtig  
herum einlegen!

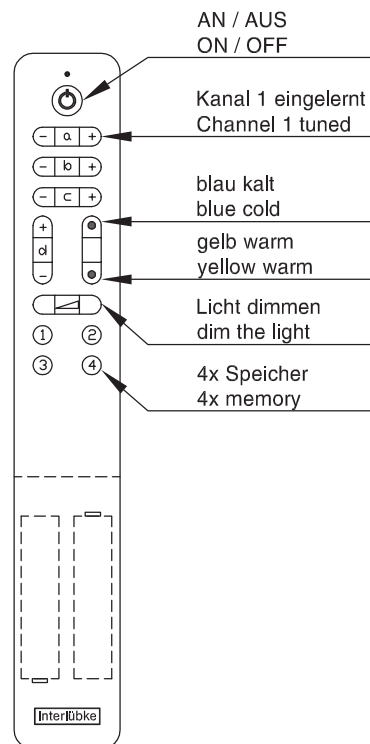

**Pflegemittel für Edelstahl silvertouch und Naturstein**  
**Maintenance products for stainless steel in silvertouch and natural stone**

**Pflegemittel für Edelstahl silvertouch und Naturstein**

Für Edelstahl silvertouch Fronten und Abdeckplatten sowie für Naturstein Abdeckplatten liefert interlübke serienmäßig Pflegemittel im Zubehörkarton mit.

Bitte überreichen Sie Ihrem Kunden die Pflegehinweise und das Pflegeöl „silverClean“ für Edelstahl silvertouch bzw. die „Natursteinpflege“ für die Naturstein-Abdeckplatten.

Herzlichen Dank!

**Maintenance products for stainless steel in silvertouch and natural stone**

For stainless steel fronts and cover panels in silvertouch respectively natural stone cover panels interlübke always supplies maintenance products in the fitting box.

Please hand over the care instructions together with the care oil “silverClean” for stainless steel in silvertouch respectively the “Natursteinpflege” for natural stone to your customer.

Many thanks!